

**VALHALLA SCIENTIFIC, INC.**

---

**MODEL 2500**  
**AC/DC CURRENT CALIBRATOR**

---

**OPERATION MANUAL**



---

**9955 MESA RIM ROAD**  
**SAN DIEGO, CA 92121**  
**(619) 457-5576**  
**(619) 457-0127 Fax**

## CERTIFICATION

---

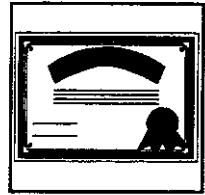

Valhalla Scientific, Inc. certifies that this instrument was thoroughly tested and inspected and found to meet published specifications when shipped from the factory. Valhalla Scientific, Inc. further certifies that its calibration measurements are traceable to the National Institute of Standards and Technology to the extent allowed by NIST's calibration facility.

## WARRANTY

---

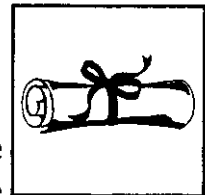

The warranty period for this instrument is stated on your invoice and packing list. Please refer to these to determine appropriate warranty dates. We will repair or replace the instrument during the warranty period provided it is returned to Valhalla Scientific, Inc. freight prepaid. No other warranty is expressed or implied. We are not liable for consequential damages. Permission and a return authorization number must be obtained directly from the factory for warranty repairs. No liability will be accepted if returned without such permission. Due to continuing product refinement and due to possible parts manufacturer changes, Valhalla Scientific reserves the right to change any or all specifications without notice.

# TABLE OF CONTENTS

---

## SECTION I: UNPACKING AND INSTALLATION



- 1-1 Introduction
- 1-2 Inspection
- 1-3 Line Voltage/Fuse Selection
- 1-4 Bench Use
- 1-5 Rack Mounting
- 1-6 Safety Precautions

## SECTION II: SPECIFICATIONS & OPTIONS



- 2-1 General
- 2-2 Accuracies
- 2-3 Operating Specifications
- 2-4 Environmental and Physical Specifications
- 2-5 Available Options

## SECTION III: OPERATION



- 3-1 General
- 3-2 Input Voltage
- 3-3 Range Switching
- 3-4 Output Current
- 3-5 Zero Adjustment
- 3-6 Overload Indicator
- 3-7 Application Information

Figure 3-1. Common Measurement Error Sources

Figure 3-2. AC Error Sources

## SECTION IV: CALIBRATION



- 4-1 General
- 4-2 Recommended Test Equipment
- 4-3 DC Calibration Procedure
- 4-4 AC Frequency Response Verification

Figure 4-1. Equipment Connections for DC Calibration

Figure 4-2. Equipment Connections for AC Compliance Test of Higher Ranges

Figure 4-3. Equipment Connections for AC Compliance Test of Lower Ranges

## **SECTION V: THEORY OF OPERATION**



- 5-1 General
- 5-2 Periodic Maintenance
- 5-3 Troubleshooting
- 5-4 Detailed Circuit Descriptions

Figure 5-1. Simplified Circuit Diagram - Transconductance Amplifier

Figure 5-2. Simplified Circuit Diagram - Overload Indicator

## **SECTION VI: MANUAL CHANGES AND ADDENDUMS**



## **SECTION VII: PARTS LISTS**



## **SECTION VIII: DRAWINGS AND SCHEMATICS**



## SECTION I UNPACKING & INSTALLATION

---



### 1-1. Introduction

The Valhalla Scientific Model 2500 AC/DC Current Calibrator is a wide-range voltage-to-current converter. This instrument will convert a precise input voltage to a proportional output current.

If the input voltage is DC, the output current will have the polarity of the input voltage. If the input voltage is AC, the output current will have the frequency, amplitude and phase characteristics of the applied input voltage. The 2500 provides seven current ranges from 1 microampere to 1 ampere which are selectable from the front-panel range switch. The legends above each push-button indicate the current produced at the output terminals when one (1.0000) volt is applied to the input terminals.

### 1-2. Inspection

If the shipping carton is damaged, request that the carrier's agent be present when the unit is unpacked. If the instrument appears damaged, the carrier's agent should authorize repairs before the unit is returned to the factory. Even if the instrument appears undamaged, it may have suffered internal damage in transit that may not be evident until the unit is operated or tested to verify conformance with its specifications. If the unit fails to operate, notify the carrier's agent and the nearest Valhalla Sales Office. Retain the shipping carton for the carrier's inspection. DO NOT return equipment to Valhalla Scientific or any of its sales offices prior to obtaining authorization to do so.

### 1-3. Line Voltage/Fuse Selection

The switch on the rear of the 2500 is used to configure the calibrator for operation at different AC line voltages. The supply voltages and their corresponding fuses are listed below:

105 to 125 VAC, 50-400Hz = 1 Amp Slo-Blo

210 to 250 VAC, 50-400Hz = ½ Amp Slo-Blo

Note: The line voltage selection is internal on instruments with serial # 6-914 or lower and requires rewiring of the transformer.

☛ Ensure that the correct line voltage selection is made prior to applying power to the 2500!

### 1-4. Bench Use

The 2500 is delivered for operation in bench use and special instructions for use in this manner other than the procedures of Section 3 are not required.

### 1-5. Rack Mounting

An optional kit is available for mounting the 2500 in a standard 19" equipment rack. This is listed in section 2-5 of this manual. If the 2500 is to be transported while mounted in a rack then it must be supported so as to prevent upward and downward movement.

The user should note that the specifications for the 2500 become degraded at high temperatures thus it is required that sufficient room be allowed

for airflow around the 2500. This may be achieved by placing a minimum 1.75" blank panel above and below the 2500 in the rack.

The entire case of the 2500 is used as a heat-sink for the output current transistors. When the instrument is installed in an equipment rack, caution should be exercised to allow a free circulation of air around the instrument. The maximum ambient air temperature within the rack must not exceed 50°C. If the internal temperature of the rack rises above this limit, forced air cooling must be employed as necessary to reduce the ambient air temperature to 50°C or lower. If a unit placed beneath the 2500 has an unusually hot exterior top surface and it is not possible to alter its location, it is recommended that an aluminum reflector plate be used between this unit and the 2500.

Under no circumstances should the ambient air temperature surrounding the 2500 be allowed to exceed 50°C while in operation or 70°C while in storage.

## 1-6. Safety Precautions

The power connector is a three-contact device and should be mated only with a three-contact connector where the third contact provides a continuous ground connection. A mating power cord has been provided. If the power is provided through an extension cable then the ground connection must be continuous throughout this cable. Failure to provide a continuous ground connection to the 2500 may render it unsafe for use!



## 2-5. Available Options

This section lists the options that may be desirable for certain applications of the Model 2500 AC/DC Current Calibrator.

### Rack Mount Adapters

*These items permit mounting of the instrument in a standard 19" equipment rack. For serial numbers 6-914 or lower, Valhalla Option "R1" is needed. For serial numbers 6-915 and greater, Option "RX-3" is needed.*

### High-Impedance Buffer Amplifier

*The Valhalla Scientific Model 2009 is a high-impedance precision buffer amplifier with a gain of 1.0000. It may be used to virtually eliminate voltmeter loading effects, and is recommended when working with load impedances greater than 1000 ohms. The Model 2009 is battery powered and has an input impedance of  $10^{10}$  ohms. See section 3-7 for application details.*

### Banana-to-Banana Leads

*Valhalla Option "BBL" is a set of 48" shielded coaxial cables terminated on both ends in standard spaced banana jacks. These leads may be used for input and output connections to the calibrator.*

### Banana-to-Clip Leads

*Valhalla Option "C" is a set of 48" shielded coaxial cables terminated on one end in a standard spaced banana jack, and on the other end with red and black alligator clips. These leads may be used for input and output connections to the calibrator.*

### Low-Thermal Leads

*Valhalla Option "SL-48" is a set of 48" shielded coaxial cables terminated on both ends in specially treated spade lugs. This lead set is designed to counteract the effects of thermals present at the terminals, and provides the best possible connection. These cables may be used for input and output connections to the calibrator.*



## SECTION II SPECIFICATIONS & OPTIONS



### 2-1. General

This section contains the accuracy and operating specifications for the Model 2500. Also included are descriptions of optional equipment available for use with the 2500.

### 2-2. Accuracies

Accuracies are valid for a period of 1 year from the date of calibration, at the calibration temperature  $\pm 5^{\circ}\text{C}$ . Outside of this range, a temperature coefficient of 10% of the accuracy specification per  $^{\circ}\text{C}$  applies. For AC accuracies, add 0.01% of (range x compliance voltage x frequency) for compliance voltages greater than 2 volts.

Range	Maximum Output	Frequency Response	Accuracies (% of output)	
			DC	AC
1 $\mu\text{A}$	2 $\mu\text{A}$	DC to 1kHz <sup>[1]</sup>	$\pm 0.01\%$ $\pm 0.4\text{nA}$	$\pm 0.05\%$ $\pm 2\text{nA}$
10 $\mu\text{A}$	20 $\mu\text{A}$	DC to 1kHz <sup>[1]</sup>	$\pm 0.01\%$ $\pm 4\text{nA}$	$\pm 0.05\%$ $\pm 20\text{nA}$
100 $\mu\text{A}$	200 $\mu\text{A}$	DC to 5kHz <sup>[1]</sup>	$\pm 0.01\%$ $\pm 40\text{nA}$	$\pm 0.05\%$ $\pm 200\text{nA}$
1mA	2mA	DC to 10kHz <sup>[1]</sup>	$\pm 0.01\%$ $\pm 400\text{nA}$	$\pm 0.05\%$ $\pm 2\mu\text{A}$
10mA	20mA	DC to 10kHz	$\pm 0.01\%$ $\pm 4\mu\text{A}$	$\pm 0.05\%$ $\pm 20\mu\text{A}$
100mA	200mA	DC to 10kHz	$\pm 0.01\%$ $\pm 40\mu\text{A}$	$\pm 0.05\%$ $\pm 200\mu\text{A}$
1A	2A	DC to 10kHz	$\pm 0.01\%$ $\pm 400\mu\text{A}$	$\pm 0.05\%$ $\pm 2\text{mA}$

Notes:

[1] Use of Valhalla Buffer Amplifier Model 2009 is recommended to eliminate voltmeter loading effects.

### 2-3. Operating Specifications

This section contains operating specifications for the Model 2500 AC/DC Current Calibrator.

Input Impedance . . . . . 100K $\Omega$   
Input:Output Ratio . . . . 1 volt produces 100% of rng output, up to 200% of rng  
Maximum Input Voltage . . . . .  $\pm 3$  volts DC or RMS  
Input CMRR . . . . . 60db @ DC, linearly decreasing to 40db @ max freq  
  
Output Compliance Voltage . . . . .  $\pm 10$ V peak;  $\pm 7$ V peak above 100% of rng  
Maximum Duty Cycle of Output . 25% @ 2 amps, increasing to 100% at 1 amp  
Output Isolation . . . . .  $\pm 200$  volts peak from LO terminal to earth  
Output Protection . . . . . 3A in-line fuse

### 2-4. Environmental and Physical Specifications

This section contains specifications pertaining to the operating environment in which the Model 2500 may be used.

Temperature Range . . . . . 0 $^{\circ}$ C to 50 $^{\circ}$ C operating; -25 $^{\circ}$ C to 70 $^{\circ}$ C storage  
Humidity . . . . . 70% RH max @ 45 $^{\circ}$ C, non-condensing  
Power Source . . . . . refer to section 1-3, 70VA max  
  
Dimensions (serial# 6-914 or lower) . . . . . 9"(23cm)D x 3"(8cm)H x 15"(38cm)W  
Dimensions (serial# 6-915 and higher) . . . 11.5"(29cm)D x 4"(10cm)H x 17"(43cm)W  
  
Weights . . . . . 15lbs(7kg) net; 20lbs(9kg) shipping



## SECTION III OPERATION

---

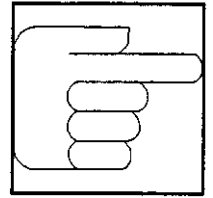

### 3-1. General

This section of the manual contains complete operating instructions for the Model 2500 AC/DC Current Calibrator. Included are control functions, connection methods, and operational precautions.

### 3-2. Input Voltage

The input voltage is applied to the left set of binding posts labeled "INPUT VOLTAGE". The polarity and level of the input voltage determine the polarity and level of the output current. If the input voltage is zero, the output current will be zero. As the input voltage is increased, the output current will increase proportionally within the selected range.

For example if the selected range is 1mA, an input voltage of 1.0000 volts DC will produce an output current of 1.0000mA. If the input is increased to 1.5000 volts, the output current will increase to 1.5000mA. Similarly, if the 10mA range is selected, the output currents will be 10.000mA and 15.000mA, respectively.

If the input voltage is of positive polarity, the output current will be of positive polarity. If the input voltage is of negative polarity, the output current will be of negative polarity. If an AC voltage is applied to the input terminals, the output current will have the amplitude, frequency and phase characteristics of the applied input voltage. The maximum input is 2 volts RMS AC or  $\pm 2.8$  volts DC.

### 3-3. Range Switching

Range switching is accomplished using the front panel push-button switch. With this switch the operator may select any one of the seven ranges of the instrument. The ranges are defined in decade increments of  $1\mu\text{A}$ ,  $10\mu\text{A}$ ,  $100\mu\text{A}$ , 1mA, 10mA, 100mA, and 1A, based on a 1-volt input level. Selection of a range is made by depressing any one button under the range marking.

### 3-4. Output Current

The output current of the calibrator is taken from the right set of binding posts labeled "OUTPUT CURRENT".

The effective output impedance of the current calibrator approaches infinity. Therefore, the output circuit will attempt to deliver the selected current into any load impedance connected to the output terminals, within compliance limits.

For example, a 1mA constant-current output applied to a  $1\text{K}\Omega$  load impedance produces a 1 volt drop across that load impedance. A 1mA output current applied to a  $2\text{K}\Omega$  load impedance produces 2 volts, etc. until the output voltage reaches the  $\pm 10$  volt DC or peak AC specified maximum compliance level for the Model 2500. This  $\pm 10\text{V}$  DC maximum compliance voltage corresponds to 7.07 volts RMS maximum compliance voltage for sinusoidal output currents.

### 3-5. Zero Adjustment

A zero adjustment has been provided and is accessible through a hole in the front panel located to the left of the range switch. The instrument should be allowed to warm up for a period of at least one hour with all covers in place prior to making a zero adjustment.

To make the zero adjustment, first short the input terminals together using a high quality connection. Select the 1mA range and connect a precision 1K $\Omega$  resistor across the output terminals. Monitor the voltage drop across this resistor with a precision voltmeter having at least 1 $\mu$ V sensitivity. If necessary, adjust the zero control until the DVM measures less than  $\pm 100$  microvolts DC.

☛ This adjustment is not required before each use, but should be checked at least once a month.

### 3-6. Overload Indicator

An overload indicator has been provided in the form of a red LED to the left of the POWER switch. It is an analog type warning system designed to inform the operator that the unit is being operated near or beyond the specification limits.

There are two possible conditions that may cause the instrument to indicate an overload. An **input overload** condition occurs when the voltage at the input terminals exceeds approximately  $\pm 2.4$  volts DC or 1.7 volts RMS AC. An **output overload** condition occurs when the voltage at the output terminals (compliance voltage) exceeds approximately  $\pm 7$  volts DC or 5 volts RMS AC.

Overload indications will occur *prior* to the point at which the specification limits have been exceeded. It is therefore possible to

have an overload indication when operating the instrument near, but not over, one of its specification limits. If the overload indicator is illuminated, a careful check of the test equipment should be made to verify proper operating conditions.

☛ Whenever the OUTPUT CURRENT terminals are open, the 2500 may indicate OVERLOAD. This occurs even if the input voltage is zero, and is a normal characteristic.

### 3-7. Application Information

The application of a precision constant-current source such as the Model 2500 AC-DC Current Calibrator requires a knowledge of potential outside error sources. The following paragraphs outline some of the more common measurement error sources.

When using the 2500, there are primarily two potential error sources. The first occurs at the voltage input to the 2500. This error occurs when the source impedance of the input voltage source,  $R_S$  shown in Figure 3-1, forms a resistor divider with the 100K $\Omega$  input impedance of the Current Calibrator,  $R_1$ . To maintain this error at 0.01% or less, the ratio of  $R_1:R_S$  must be maintained at 10,000:1 or greater. Since  $R_1$  equals 100K $\Omega$ , the maximum impedance for  $R_S$  must be less than 10 $\Omega$ .

The second potential error source occurs at the current output of the 2500. This error source is the input impedance of the DVM,  $R_Z$  shown in Figure 3-1, in parallel with the load impedance,  $R_L$ . To maintain the error at 0.01% or less, the ratio of  $R_Z:R_L$  must be maintained at 10,000:1 or greater. If the input impedance to the DVM is 10 megohms, the maximum shunt impedance,  $R_L$ , must not exceed 1K $\Omega$ .



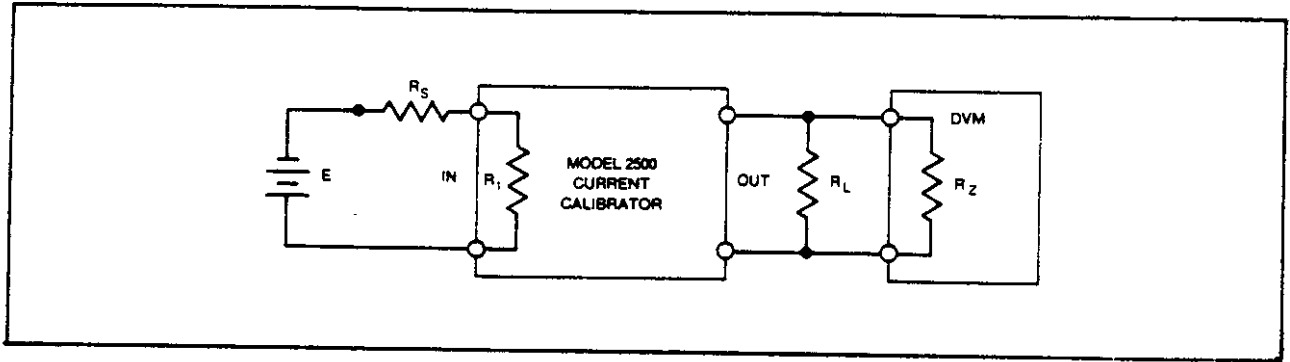

**Figure 3-1. Common Measurement Error Sources**

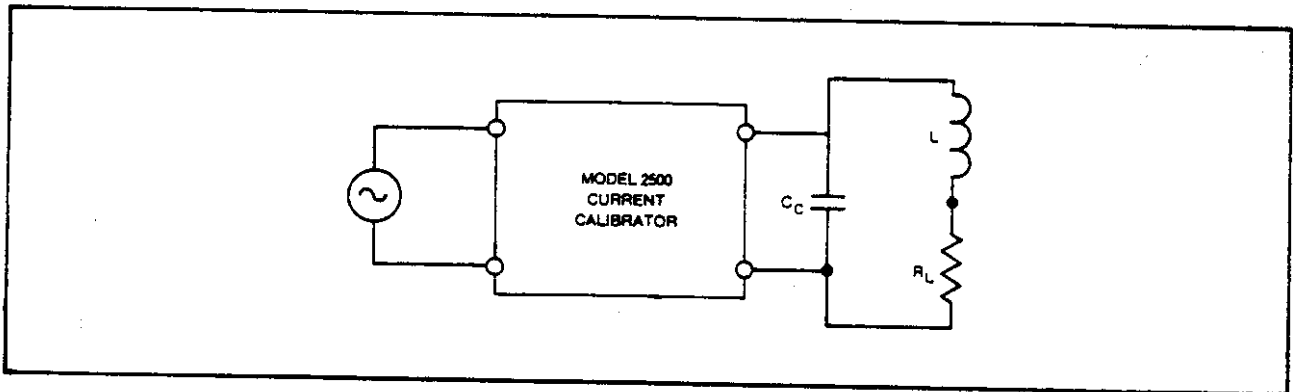

**Figure 3-2. AC Error Sources**



For an  $R_L$  of 1 megohm, the input impedance of the DVM ( $R_Z$ ) must be at least 10,000 megohms. This commonly exceeds voltmeter input specifications. To eliminate this error source, Valhalla offers an optional precision buffer amplifier, the Model 2009. See section 2-5 for details.

In addition to the error sources outlined above, there are other sources to be considered when measuring AC current. The most common of the AC error sources is cable capacitance, shown in Figure 3-2 as  $C_C$ .

As an example, RG58/U cable has a capacitance of approximately 30 picofarads per foot. If the output of the 2500 is connected to the load resistance through two feet of cable, the cable capacitance is 60 picofarads. If the output frequency is 10 KHz and  $R_L$  is 100K $\Omega$ , the effective load impedance ( $Z$ ) is:

$$Z = \frac{R_L \left( \frac{1}{2\pi \cdot 10\text{KHz} \cdot 60\text{pf}} \right)}{\sqrt{R_L^2 + \left( \frac{1}{2\pi \cdot 10\text{KHz} \cdot 60\text{pf}} \right)^2}} = 93.571\text{K}\Omega$$

### EQUATION 3-1. Lead Capacitance

The effective error due to shunt capacitance in this example is 6.43%. As shown in Equation 3-1, shunt capacitance versus load impedance is a square-law function. Reducing the load impedance by a factor of 10 (from 100K $\Omega$  to 10K $\Omega$ ) will reduce the error by 100:1 (from 6% to 0.06%).

Another potential error source is inductance ( $L$ ) in series with the load resistor,  $R_L$ . In a typical example, the load resistance is 1 $\Omega$  and the series inductance is 5 microhenries. The effective load impedance ( $Z$ ) at 10 KHz is:

$$Z = \sqrt{R_L^2 + (2\pi \cdot 10\text{KHz} \cdot 5\mu\text{H})^2} = 1.0481\Omega$$

### EQUATION 3-2. Series Inductance

The effective error in load impedance caused by series inductance is, in this case, 4.81%. A precise current output from the Current Calibrator of 1.0000 amperes RMS at 10 KHz, when applied to this load, will produce a voltage drop of 1.0481 volts RMS. In actual practice, series inductance becomes a problem only for shunt impedances of less than 5 $\Omega$  at frequencies of 10 KHz.

Due to this phenomenon, the series inductance of most of the commercially available lab-standard type 1 ohm resistors is not low enough to produce accurate results when the output current is 1 ampere at 10 KHz. Special non-inductive precision current shunts are required.

☛ In summary, take note of lead capacitance and voltmeter loading when working with high resistances (>1K $\Omega$ ). Take note of series inductance when working with AC currents and low load resistances (<5 $\Omega$ ).

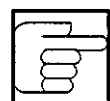

## SECTION IV CALIBRATION

---

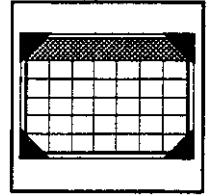

### 4-1. General

The following procedures should be performed at routine intervals to ensure that the 2500 remains within specified limits. In addition, calibration should be performed following repairs involving accuracy determining components.

Remove the screws from the top cover of the unit to gain access to the internal adjustments, but leave the cover resting in place for maximum stability. The locations of the adjustments are listed on drawing number 2500-600 at the back of this manual. Apply power to the 2500 and test equipment and allow approximately 1 hour for stabilization.

Note that the instrument may also be returned to the factory for full calibration traceable to NIST.

### 4-2. Recommended Test Equipment

1. Valhalla Scientific 2701C DC Voltage Standard (or equivalent: 0 - 2 volts DC,  $\pm 0.003\%$  accuracy)
2. 5-Digit DVM, Hewlett Packard 3458A or equivalent,  $\pm 0.003\%$  accuracy, 10 Megohms input impedance @ 1VDC
3. Precision DC shunt resistors with known values to within  $\pm 0.003\%$ :

1.0000 $\Omega$   
10.000 $\Omega$   
100.00 $\Omega$   
1.0000K $\Omega$   
10.000K $\Omega$   
100.00K $\Omega$   
1.0000M $\Omega$

4. Semi-Precision DC Resistors ( $\pm 1\%$ ):

9 $\Omega$ , 10W  
90 $\Omega$ , 1W  
900 $\Omega$ ,  $\frac{1}{2}$ W  
9K $\Omega$ ,  $\frac{1}{4}$ W

5. DC Nullmeter with 10 microvolts sensitivity

If the AC frequency response test is to be conducted, the following items of AC test equipment will also be required:

1. Thermal transfer system, Fluke Model 540 or equivalent, with current shunts for 1A, 0.1A and 0.01A
2. Precision AC Voltmeter, Hewlett Packard 3458A or equivalent
3. Valhalla Scientific Model 2703, AC Voltage Standard (or equivalent: 0 - 2V, 100Hz - 10KHz with  $\pm 0.03\%$  accuracy)
4. High impedance AC Buffer Amplifier, Valhalla Scientific Model 2009, or equivalent having an input impedance of  $10^{10}$  ohms or greater
5. AC Shunts with known values to within  $\pm 0.005\%$ :

1.0000K $\Omega$   
10.000K $\Omega$   
100.00K $\Omega$

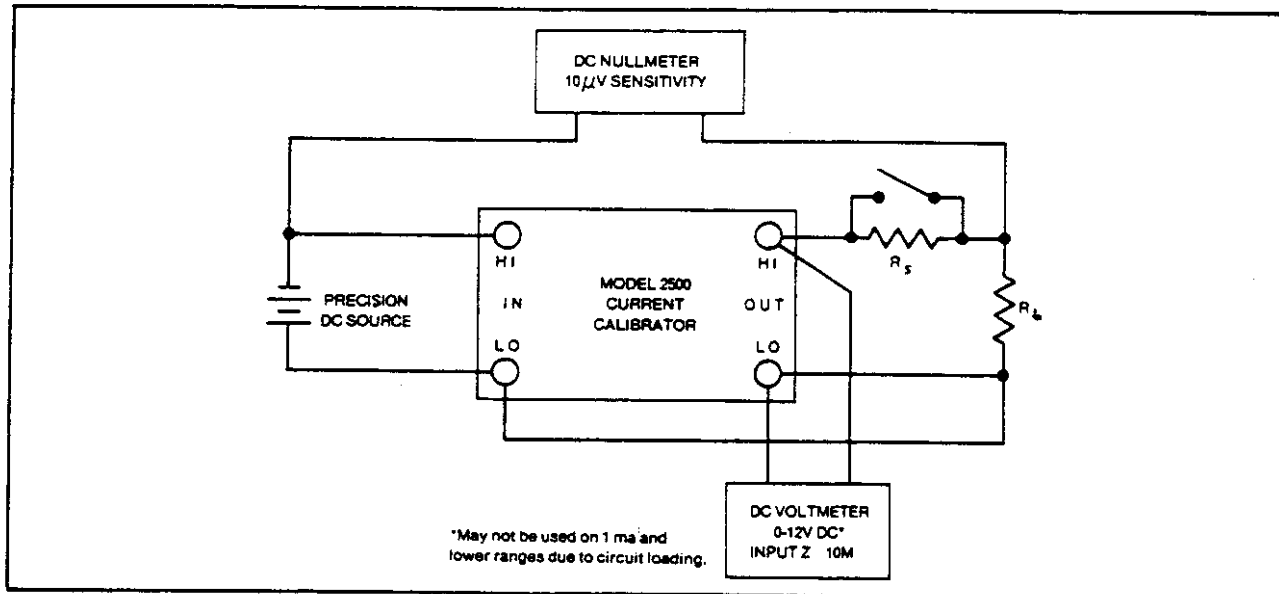

Figure 4-1. Equipment Connections for DC Calibration

### 4-3. DC Calibration Procedure

The following procedure is the routine DC adjustment procedure. The 2500 is calibrated at DC, then may be verified for AC response in section 4-4.

#### 4-3-1. 1A Range Adjustment

Connect the equipment as shown in the diagram of Figure 4-1 using the 1.0000 ohm resistor for  $R_L$  and the 9 ohm resistor for  $R_S$ . Set the DC Voltage standard to zero volts DC. Select the 1A range on the Model 2500 and adjust the front panel ZERO control for an indication on the DC nullmeter of  $\pm 100$  microvolts or less.

Set the DC voltage standard for 1.0000 volts DC. Adjust R48 for an indication on the nullmeter of  $\pm 100$  microvolts or less. Open and close the switch across  $R_S$ . The output voltage displayed on the DVM should change from 1 volt to 10 volts.

Open and close the switch across  $R_S$  and observe the direction and magnitude of change indicated on the nullmeter. Adjust R54 for a nullmeter reading change of less than  $\pm 100$  microvolts between the open

and closed positions of the switch. The total offset of the output generated by adjusting R54 can be ignored. Only the change in the reading between switch positions is of importance at this point. After adjusting R54, return to the beginning of Section 4-3-1 and repeat the procedure.

Note: If the DC nullmeter reads less than  $\pm 200$  microvolts at both positions of the switch, proceed to section 4-3-2.

#### 4-3-2. 100mA Range Adjustment

Connect a 10.000 ohm resistor for  $R_L$  and a 90 ohm resistor for  $R_S$ . Select the 100mA range and set the DC voltage standard to zero volts DC. Check for an indication of less than  $\pm 100$  microvolts on the nullmeter. Adjust the front panel ZERO control, if required.

Set the DC voltage standard to 1 volt DC. Adjust R47 for an indication on the nullmeter of less than  $\pm 200$  microvolts with the switch open and closed.



The output compliance voltage need not be monitored during the remainder of the calibration procedure. Remove the DVM as it will cause loading errors if it is connected during the remainder of the calibration procedure. If it is desirable to use the DVM to monitor the output, a buffer must be used such as the Valhalla Model 2009.

#### 4-3-3. 10mA Range Adjustment

Select the 10mA range and connect a 100.00 ohm resistor for  $R_L$  and a 900 ohm resistor for  $R_S$ . Set the DC voltage standard for zero volts DC. Check for an indication on the nullmeter of less than  $\pm 100$  microvolts. Adjust the front panel ZERO control, if required.

Set the DC voltage standard to 1 volt DC. Adjust R46 for an indication on the nullmeter of less than  $\pm 200$  microvolts with and without the switch shorting  $R_S$ .

#### 4-3-4. 1mA Range Adjustment

Select the 1mA range and connect a 1.0000K ohm resistor for  $R_L$  and a 9K ohm resistor for  $R_S$ . Set the DC voltage standard to zero volts DC. Check for an indication on the nullmeter of less than  $\pm 100$  microvolts. Adjust the front panel ZERO control, if required.

Set the DC voltage standard to 1 volt DC. Adjust R38 for an indication on the nullmeter of  $\pm 200$  microvolts with and without the switch shorting  $R_S$ .

#### 4-3-5. 100 $\mu$ A Range Adjustment

Select the 100 $\mu$ A range and connect a 10.000K ohm resistor for  $R_L$  and close the switch across  $R_S$ . Set the DC voltage standard to zero volts DC. Check for an indication on the nullmeter of  $\pm 100$

microvolts, or less. Adjust the front panel ZERO control, if required.

Set the DC voltage standard to 1 volt DC. Adjust R40 for an indication on the nullmeter of  $\pm 200$  microvolts or less.

#### 4-3-6. 10 $\mu$ A Range Adjustment

Select the 10 $\mu$ A range and connect a 100.00K $\Omega$  resistor for  $R_L$  and close the switch across  $R_S$ . Set the voltage standard to zero volts DC. Check for an indication on the nullmeter of  $\pm 100$  microvolts or less. Adjust the front panel ZERO control, if required.

Set the DC voltage to 1 volt DC. Adjust R42 for an indication on the nullmeter of  $\pm 200$  microvolts or less.

#### 4-3-7. 1 $\mu$ A Range Adjustment

Select the 1 $\mu$ A range and connect a 1.0000M $\Omega$  resistor for  $R_L$  and close the switch across  $R_S$ . Set the voltage standard to zero volts DC. Check for an indication on the nullmeter of  $\pm 100$  microvolts or less. Adjust the front panel ZERO control, if required.

Set the voltage standard to 1 volt DC. Adjust R42 for an indication on the nullmeter of  $\pm 200$  microvolts or less.

#### 4-4. AC Frequency Response Verification

The frequency response test need not be performed on a routine basis as the 10kHz bandwidth is inherent in the design of the 2500. The frequency response test is an exacting procedure requiring the specialized test equipment listed in section 4-2. This equipment is not usually found in most service laboratories.



Before attempting to perform this test it is recommended that section 3-7 be completely reviewed so that the operator thoroughly understands the sources of errors and compensates for them during the test. If test equipment other than those listed is to be used, a comparison of the specifications for the equipment listed and that to be used must be made to ensure that the equipment used is a precise equivalent.

#### 4-4-1. 1A Range Verification

Connect the Fluke A40-1 (1 Ampere shunt) to the output of the Model 2500 AC-DC Calibrator and to the input of the Fluke 540 Thermal Transfer system as shown in Figure 4-2.

Set the Model 540 Mode switch in the AC transfer position and the range switch to shunt.

Select the 1A range on the Model 2500 and apply 1V RMS at 100 Hz from the AC voltage standard to the input of the Model 2500. Null the galvanometer on the Model 540 to zero.

Increase the frequency of the AC voltage standard to 1000Hz, 5KHz, and 10KHz and verify that at no point does the change in output exceed the specifications of Section 2-2.

#### 4-4-2. 100mA Range Verification

Connect the Fluke Model A40-0.1 (100 milliampere) shunt in place of the A40-1. Repeat the steps outlined in section 4-4-1, substituting the 100mA range inputs and specifications.

#### 4-4-3. 10mA Range Verification

Connect the Fluke Model A40-0.01 in place of the 0.1. Repeat the steps outlined in section 4-4-1, substituting the 10mA range inputs and specifications.

#### 4-4-4. 1mA Range Verification

Connect the equipment as shown in Figure 4-3 using the 1.0000K $\Omega$  shunt. The total shunt capacitance including leads and resistor capacitance must not exceed 200 picofarads.

Apply 1V RMS at 100 Hz to the input of the Model 2500 and record the DVM reading.

Increase the frequency of the AC voltage standard to 1000Hz, 5KHz, and 10KHz and verify that the change in DVM reading does not exceed the specifications in section 2-2 at any frequency.

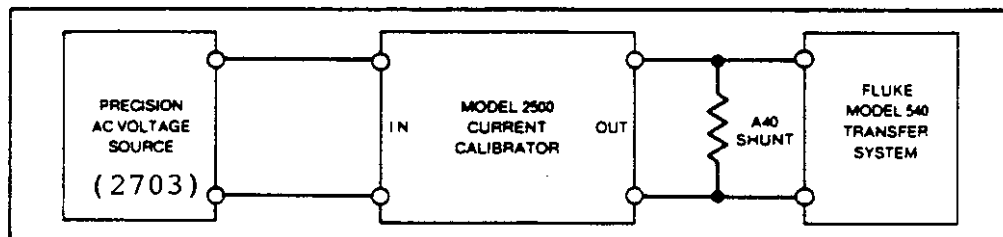
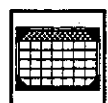
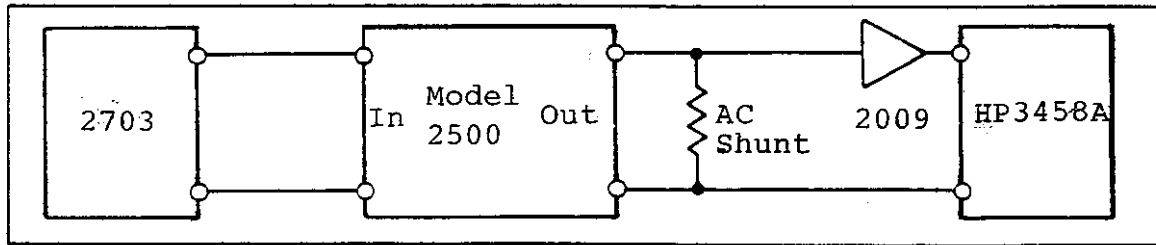

Figure 4-2. Equipment Connections for AC Compliance Test of Higher Ranges





**Figure 4-3. Equipment Connections for AC Compliance Test of Lower Ranges**

#### **4-4-5. 100 $\mu$ A Range Verification**

Connect the equipment as shown in Figure 4-3 using the 10.000K $\Omega$  shunt. Total shunt capacitance including leads and resistor capacitance must not exceed 20 picofarads.

Apply 1V RMS at 100 Hz to the input of the Model 2500 and record the DVM reading.

Increase the frequency of the AC voltage standard to 1000Hz and 5Khz and verify that the change in DVM reading does not exceed the specifications in Section 2-2.

#### **4-4-6. 10 $\mu$ A Range Verification**

Connect the equipment as shown in Figure 4-3 using the 100.00K $\Omega$  shunt. Total shunt capacitance, including leads and resistor capacitance, must not exceed 2 picofarads.

Apply 1V RMS at 100 Hz to the input of the Model 2500 and record the DVM reading.

Increase the frequency of the AC voltage standard to 1000Hz and verify that the change in DVM reading does not exceed the specifications in Section 2-2.

#### **4-4-7. 1 $\mu$ A Range Verification**

Connect the equipment as shown in Figure 4-3 using the 100.00K $\Omega$  shunt. Total shunt capacitance, including leads and resistor capacitance, must not exceed 2 picofarads. Return the AC voltage standard to 100 Hz. Record the reading on the DVM.

Increase the AC voltage standard frequency to 1000 Hz. Verify that the change in DVM reading does not exceed the specifications of Section 2-2. If the readings at 1000 Hz are out of tolerance, C13 on the 1 $\mu$ A range switch may be adjusted to bring the readings within tolerance.



## SECTION V THEORY OF OPERATION

---



### 5-1. General

The following paragraphs provide the information required to perform the required periodic maintenance and basic guidelines for troubleshooting the 2500.

### 5-2. Periodic Maintenance

The 2500 requires little periodic maintenance other than regular performance of the calibration procedure of Section 4. Maintenance which may be required is discussed in the following paragraphs.

#### 5-2-1. Cleaning

It is recommended that the 2500 be operated in a clean environment. However, if the environment is dusty periodic cleaning of the unit will be necessary.

Loose dirt or dust which has collected on the exterior surfaces of the 2500 may be removed with a soft cloth or brush. Any remaining dirt may be removed with a soft cloth dampened in a mild soap and water solution. **Do not use abrasive cleaners.**

The front panel may be cleaned with a soft cloth and a "Windex" type cleaner. **Do not use petroleum based cleaners on the front panel.**

If required, the 2500 interior may be cleaned by blowing with dry compressed air.

If the 2500 has become heavily soiled with dirt or by other contaminants it is recommended that the unit be completely overhauled. Contact your local Valhalla

Scientific Service Center for details.

### 5-3. Troubleshooting

The following paragraphs give basic procedures for troubleshooting and component replacement in the 2500.

#### 5-3-1. Component Replacement

The 2500 accuracy and reliability can only be maintained if the following precautions are taken when changing a component:

- ▲ Remove all power from the instrument and input terminals before attempting component replacement.
- ▲ Use only the specified component or its exact equivalent. Spare parts may be ordered from your nearest Valhalla Scientific Service Center by referring to the Valhalla part number listed in the Parts List section at the back of this manual. Please provide the type and serial number of the instrument with your order.
- ▲ Use only 63/37 rosin core electronic grade solder with a 50W (or lower) maximum power soldering iron.
- ▲ Some of the semiconductor devices used in the 2500 can be damaged by static discharges. The user should follow strict static-free procedures to ensure that damage does not occur.
- ▲ When resoldering components the user must ensure that the highest possible quality soldering is used. A dry joint may cause the 2500 to



drift outside of its specification limits.

- ▲ Minimize handling of components and assemblies. Transport and store components in the original containers.
- ▲ Discharge static build-up on the user and instrument prior to handling components or assemblies.
- ▲ Handle the components such that all (or as many as possible) of the leads are in contact with the user.
- ▲ Never slide a component over a surface.
- ▲ Use a grounded tip soldering iron and ensure that the assembly being (de)soldered is also grounded.

### 5-3-2. Finding the Faulty Component

- ☛ Avoid contact with power wiring and hazardous line voltages!

Experience has shown that apparent malfunctions are often the result of misinterpretation of the specifications or operating procedures of the unit. Check to be sure that the cables and other test equipment are in good order before attempting to repair the 2500. A review of section 3-7 of this manual is also recommended.

Knowledge of circuit operation is a prerequisite for efficient fault finding in the 2500. Certain questions should be asked that will help isolate the problem as much as possible. These questions include determining whether the problem occurs on only one range, or on all ranges. An AC-only problem may differ from a DC problem. The detailed descriptions in this section will help explain circuit operation down to component level.

### 5-3-3. Amplifier Servicing

The following procedure is provided as an aid to isolate a catastrophic malfunction to a local area:

Short the input terminals and short the output terminals. With a differential DC voltmeter, measure the voltage between the anode of CR15 and pin 6 of IC3. This voltage must be less than 15 millivolts. If it is more than 15 millivolts, IC3 is most likely defective. If it is less than 15 millivolts, the malfunction is in the second amplifier (and/or the current amplifiers), or the feedback network.

Note: If IC3, IC4, Q7, Q8 or R34 through R44 are replaced, the AC Frequency Response Test must be performed. Contact Valhalla Scientific if the AC frequency response test results are not satisfactory.

### 5-4. Detailed Circuit Descriptions

This section describes the operation of each circuit down to component level. The reference designators used in this section are those of the schematic diagram of the Model 2500, drawing number 2500-070 at the back of this manual.

#### 5-4-1. Power Supplies

The  $\pm 18V$  power supplies are formed by CR16 - CR23 and C9 - C10. These supplies are unregulated and the voltage will vary depending on line voltage and load.

The  $\pm 15$  volt supplies are regulated from the  $\pm 18$  volt supplies above. IC5 regulates the +15 volts and IC6 regulates the -15 volts. The exact values vary depending on the component, but are typically 14.8-15.2 volts.



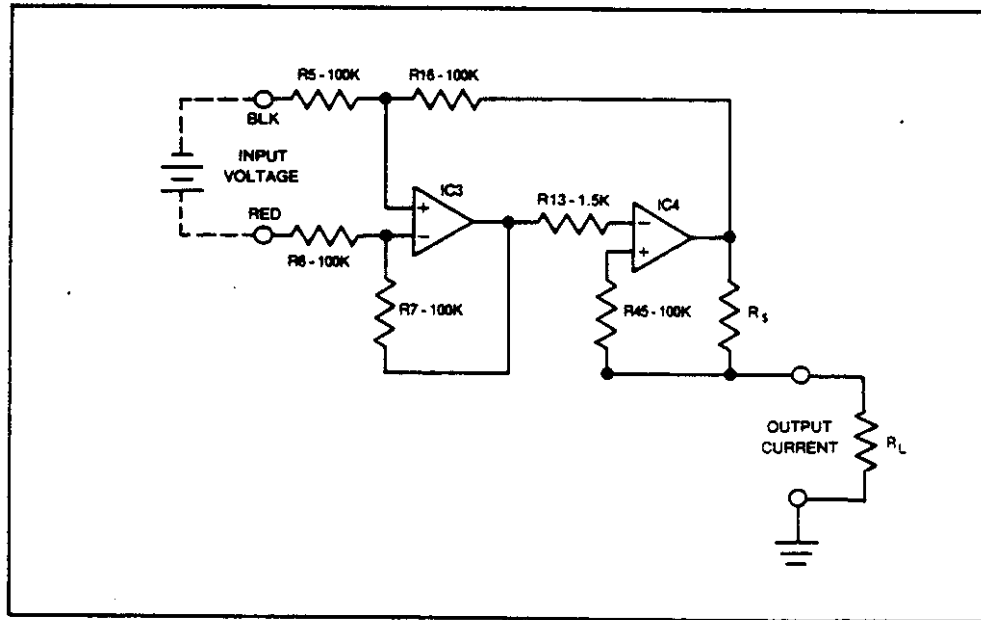

Figure 5-1. Simplified Circuit Diagram - Transconductance Amplifier

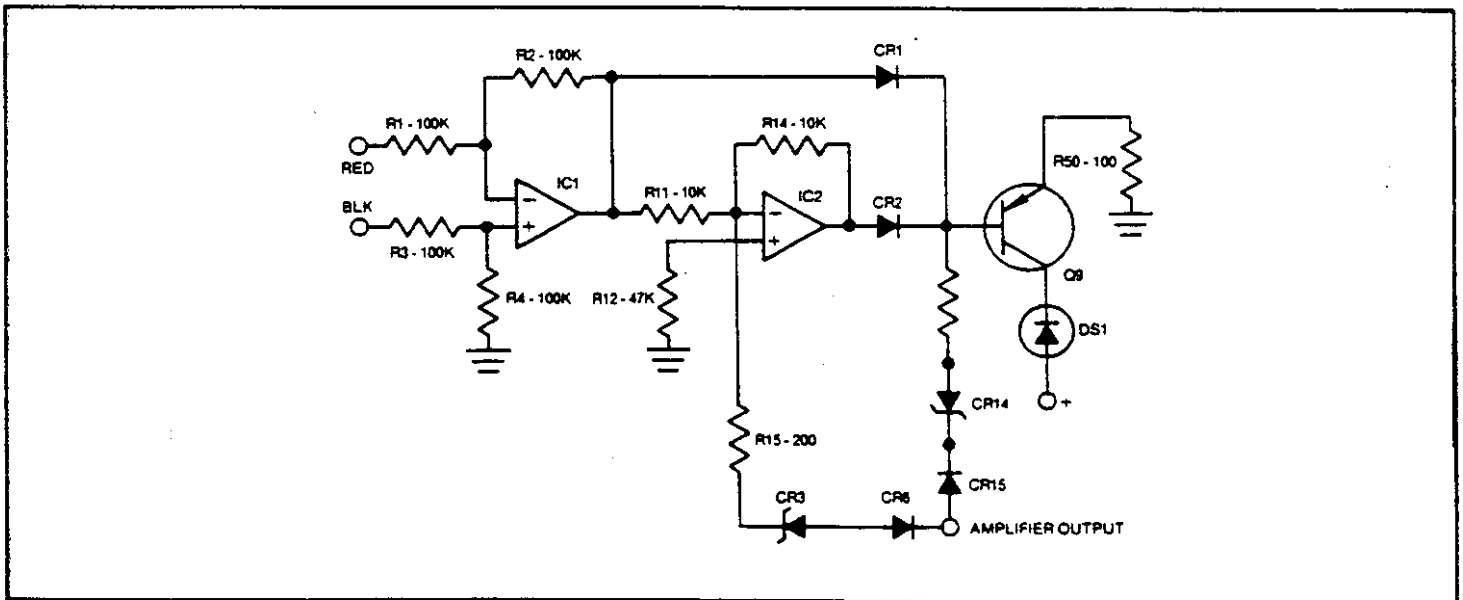

Figure 5-2. Simplified Circuit Diagram - Overload Indicator



## 5-4-2. Voltage-to-Current Converter

(Transconductance Amplifier, U.S. Patent 4,091,333)

A simplified diagram of the voltage-to-current converter is shown in Figure 5-1. The first amplifier operates at unity gain by virtue of the operational feedback loop provided by R7. The output of the first amplifier drives the inverting input of the second amplifier which operates open loop and therefore at very high gain. The output of the second amplifier provides a potentiometric feedback to the non-inverting input of the first amplifier. The system operates to maintain the output of the first amplifier and the inverting input of the second amplifier at approximately the same potential as that applied to the non-inverting input of the second amplifier. Very small differences between the two inputs of the second amplifier are sufficient to drive it to full scale output.

Assume that the output terminals are shorted and 1 volt DC potential is applied to the input with the red input terminal positive. To equalize the inputs to the second amplifier, the first amplifier output must be driven to zero. This will be accomplished when the voltage drop across each of the four resistors (R5, R6, R7, and R16) is 0.25 volts. This condition will be satisfied when the output of the second amplifier is at +1 volt. The inputs to the first amplifier will both be at 0.25 volts and, since they are equalized, the output will be zero (offset, of course, the very small amount necessary to drive the output of the second amplifier to +1 volt). +1 volt at the output of the second amplifier will cause 1 milliamperes to flow through the 1k $\Omega$  series resistor, R<sub>S</sub>. Any tendency toward increasing the output voltage of the second amplifier is immediately compensated for through the feedback from its output to the non-inverting input of the first amplifier. Note that the sum of the voltages across the four resistors equals the voltage applied to the input terminals.

Consider the conditions that are obtained when the short is removed from the output terminals and a 1K $\Omega$  resistor is connected between the output terminals. The reference level to the non-inverting input of the second amplifier will now be at some point above ground due to the current flowing through the load resistor R<sub>L</sub>. This will drive the output of the second amplifier in a positive direction and a point of stability will be reached when the output of the first amplifier is equal to the level applied to the non-inverting input of the second amplifier.

Again, this condition will be obtained when the voltage drops across each of the four resistors in the loop are equal to 0.25 volts. This will require that the output of the first amplifier be driven to +1 volt and the output of the second amplifier to +2 volts. Two volts across the series combination of R<sub>S</sub> and R<sub>L</sub> will produce one milliamperes of current. Thus, although the resistance across the output terminals has been increased from zero to 1K $\Omega$ , the current flowing through the output terminals remains at one milliamperes for both conditions.

Note that the voltage difference between the output of the first amplifier and the output of the second amplifier is always equal to the voltage applied to the input terminals of the system. If the input signal were increased to +2 volts DC, the potential difference between the output of the first amplifier and the output of the second amplifier would increase to 2 volts and the voltage drop across the four resistors, to achieve equilibrium, would be 0.5 volts. If a 1K resistor is connected across the output terminals, the output of the second amplifier would be increased to +4 volts and the current through the series combination of R<sub>S</sub> and R<sub>L</sub> would increase to 2 milliamperes. Thus, the output current would be maintained proportional to the input voltage.



Since the system tends to maintain a voltage at the output of the second amplifier proportional to the input voltage, selecting different values of  $R_S$  with the front panel range switch will result in different current levels through  $R_S$  and the output load.

The second amplifier is comprised of a high gain amplifier integrated circuit followed by a transistorized current amplifier in a "totem pole" arrangement. This provides positive and negative current outputs and has the capacity to deliver up to 2 amperes to the load.

Q3 and Q4 operate as constant-current sources to bias Q5 and Q6. R54, which is connected to the non-inverting input of IC3, provides a fine adjustment for the overall gain of the voltage-to-current converter. R8 provides an adjustment to compensate for the inherent offset of IC3.

#### 5-4-3. Overload Indicator

The overload indicator circuit is shown in Figure 5-2. It checks for two conditions simultaneously: *input overload* and/or *output overload*.

The input voltage is applied to inputs of IC1 through R1 and R3. IC1 operates as a differential operational amplifier with unity gain. The output of IC1 drives the inverting input of IC2, which also operates at unity gain. The output of IC1 will go positive with a negative input voltage and the output of IC2 will go positive with a positive input voltage. If the input voltage (DC or peak AC) exceeds approximately 2.4 volts, Q9 will be turned on and DS1 illuminated when the output voltage exceeds the threshold of CR14 and the drop across CR15, which approximates +7 volts DC or peak AC.

Q9 will also be turned on in the output overload mode when the output goes negative and exceeds the threshold of

zener diode CR3 and the drop across CR6 which will occur at approximately -7 volts DC or peak AC. CR3 is connected to the inverting input of IC2 to drive the output of IC2 positive and turn on Q9 through CR2.

#### 5-4-4. Range Selection

Range selection is accomplished using a 7-station push-button interlocking switch assembly. This switch inserts different values of resistance for  $R_S$ , shown in Figure 5-1, for each range.

Calibration potentiometers in the resistor matrix permit precise adjustment of output current for a given input voltage. The adjustment of these potentiometers is discussed in the calibration procedure of Section 4.



## **SECTION VI    MANUAL CHANGES AND ADDENDUMS**

---

This section contains any additional information regarding special modifications to the Calibrator or changes to the Operation Manual. If no addendums follow this page, your manual is complete as printed.



## SECTION VII PARTS LISTS

---

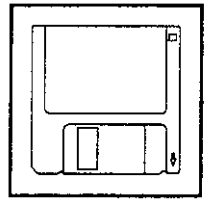

The following parts lists have been included in this manual:

2500 Final Assembly ..... 2500-400

REF.DES.	STOCK #	QUANTITY			DESCRIPTION	MANUFACTURING/PURCHASING DATA
		A	T	N		
1	04-30007	1			2500 Main Board	DWG 2500-700
2	04-30008	1			2500 Power Supply Board	DWG 2500-701
3	04-10911		2		2790 Top & Bottom Cover	DWG 2790-228
4	04-11004	1			Universal Mounting Plate	DWG 4100-218
5	04-10546	1			2500 Front panel (screened)	DWG 2500-100 using 04-10024
6	04-10460	2			2790 Side Rail	DWG 2790-206
7	04-10019	2			2500 Heat sink	DWG 2500-203
8	04-10022	1			2500 Rear panel	DWG 2500-204
9	05-10015	4			Foot, rubber, white	Acc. Rubber 2089W-017
10	05-10218	1			Hole plug	Calmark 810-25 BLACK
12	05-10005	5			Standoff, swage, 1/4 od, 3/16 lg, 6-32	Useco B15308-3/16-11
14	05-10004	2			Fuse clip, P.C.B. mount	Little fuse 101002
17	05-10073	8			Knob, black, rectangular	Centralab B304-BLK
18	91-08005	4			#8-32 x 5/16" Phil Flat S.S. 82 Deg.	
19	90-06010	4			#6-32 x 5/8" Phil Pan S.S.	
20	90-06005	10			#6-32 x 5/16" Phil Pan S.S.	
21	93-06408	8			#6-32 x 1/2" Slot Pan Black Nylon	
22	90-04003	2			#4-40 x 3/16" Phil Pan S.S.	
23	80-02520	6			20awg Wire, Green TFE	M16878/4-BGE-5
24	91-06004	17			#6-32 x 1/4" Phil Flat 82 Deg. S.S.	
26	98-04002	2			#4 Internal Star Washer S.S.	
27	98-06002	10			#6 Internal Star Washer, S.S.	
28	97-06001	1			#6-32 Hex Nut, SMALL PATTERN, S.S.	
29	97-04001	2			#4-40 Radio Hex Nut S.S.	
30	80-02118	8			18awg wire, brown TFE	M16878/4-BHE/1
31	80-02418	8			18awg wire, Yellow TFE	M16878/4-BHE-4
32	80-01512	6			12awg Wire, Green PVC	M16878/1-BLE-5
33	80-01712	6			12awg Wire, Violet PVC	M16878/1-BLE-7
34	80-00022	9			22awg Bus Wire	1BB-2201 ANIXTER
36	80-10058	5			RG58 Coax Cable	Anixter RG58C/U
37	70-00004	5			1/4" Black Shrink Tubing FP301	3M 3000250BK
38	99-06000	4			#6 18-22awg Ring Lug (Red)	PANDUIT PV18-6R
39	99-06100	2			#6 14-16awg Ring Lug (Blue)	PANDUIT PV14-6B
40	99-10100	1			#10 14-16awg Ring Lug (Blue)	PANDUIT PV14-10B
41	70-00006	5			3/8" Black Shrink Tubing	3M 3000375BK
42	05-10086	1			Solder lug, #6, internal star	Smith 1412-6
43	80-02222	4			22awg Wire, Red TFE	M16878/4-BFE-2
44	80-02922	4			22awg Wire, White TFE	M16878/4-BFE-9
45	80-02322	12			22awg Wire, Orange TFE	M16878/4-BFE-3
46	70-11022	9			22awg TFE Sleeving	ATC TFT 22
47	04-10875	1			Heatsink Insulator	DWG 2500-228
C1	02-10005	1			50pF 500V Ceramic disc	Illinois 500BCR050K
C2	02-30001	1			10uF 25V Tantalum Bead	AVX TAP106K025SP
C3	02-10001	1			200p 100V Ceramic disc	Sprague 5GAT20
C4	02-10005	1			50pF 500V Ceramic disc	Illinois 500BCR050K
C5	02-30001	1			10uF 25V Tantalum Bead	AVX TAP106K025SP
C6	02-60002	1			0.1u 250V Mylar	Illinois 104MSR250K
C9	02-40002	1			10000u 50V Aluminum	Mallory CGS103U050V2C
C10	02-40002	1			10000u 50V Aluminum	Mallory CGS103U050V2C
C12	02-10005	1			50pF 500V Ceramic disc	Illinois 500BCR050K
C13	02-70004	1			12-100pF Top Adjust	Mouser 24AA067

REF.DES.	STOCK #	QUANTITY			DESCRIPTION	MANUFACTURING/PURCHASING DATA
		A	T	N		
C14	02-60001	1			0.22u 100V Mylar	Illinois 224SHR100K75CE
C15	00-00000		1		Factory Select Part	
CR1	03-20000	1			Diode, general purpose	1N4148 or 1N914
CR2	03-20000	1			Diode, general purpose	1N4148 or 1N914
CR3	03-20005	1			Diode, Zener, 6.2V, 10%	1N5234
CR4	03-20031	1			Diode, zener, 4.7V, 10%, 5watts	1N5337A
CR5	03-20031	1			Diode, zener, 4.7V, 10%, 5watts	1N5337A
CR6	03-20000	1			Diode, general purpose	1N4148 or 1N914
CR7	03-20000	1			Diode, general purpose	1N4148 or 1N914
CR8	03-20000	1			Diode, general purpose	1N4148 or 1N914
CR9	03-20000	1			Diode, general purpose	1N4148 or 1N914
CR10	03-20000	1			Diode, general purpose	1N4148 or 1N914
CR11	03-20000	1			Diode, general purpose	1N4148 or 1N914
CR12	03-20000	1			Diode, general purpose	1N4148 or 1N914
CR13	03-20000	1			Diode, general purpose	1N4148 or 1N914
CR14	03-20005	1			Diode, Zener, 6.2V, 10%	1N5234
CR15	03-20000	1			Diode, general purpose	1N4148 or 1N914
CR16	03-20002	1			Diode, rectifier, 1A, 50V	1N4001-1N4007
CR17	03-20002	1			Diode, rectifier, 1A, 50V	1N4001-1N4007
CR18	03-20002	1			Diode, rectifier, 1A, 50V	1N4001-1N4007
CR19	03-20002	1			Diode, rectifier, 1A, 50V	1N4001-1N4007
CR20	03-20002	1			Diode, rectifier, 1A, 50V	1N4001-1N4007
CR21	03-20002	1			Diode, rectifier, 1A, 50V	1N4001-1N4007
CR22	03-20002	1			Diode, rectifier, 1A, 50V	1N4001-1N4007
CR23	03-20002	1			Diode, rectifier, 1A, 50V	1N4001-1N4007
DS1	05-01036	1			LED Indicator, Red, Panel mtg with leads	5110F1
DS2	05-01026	1			Neon Lamp, Panel Mount 115VAC, w/resistor	IDI, IDI2150A1
F1	05-04003	1			3A, Fuse	Littlefuse, 312-003
F2	05-04002	1			1A, Slo Blo Fuse	Littlefuse, 313-001
FH1	05-10018	1			Fuseholder, panel mount	Littlefuse 345061
IC1	03-30013	1			Op-Amp, General Purpose, Uncompensated	LM301AH or LM301AN
IC2	03-30013	1			Op-Amp, General Purpose, Uncompensated	LM301AH or LM301AN
IC3	03-30117	1			Precision JFET Op-amp	National LH0052H
IC4	03-30117	1			Precision JFET Op-amp	National LH0052H
IC5	03-30036	1			Regulator, +15V, 0.5A, TO202 or TO220	78M15CP or LM340T-15
IC6	03-30037	1			Regulator, -15V, 0.5A, TO202 or TO220	79M15CP or LM320T-15
J1	05-10001	1			Binding post, red	Superior BP21RC
J2	05-10002	1			Binding post, white	Superior BP21WTC
J3	05-10001	1			Binding post, red	Superior BP21RC
J4	05-10002	1			Binding post, white	Superior BP21WTC
J5	05-10063	1			Connector, AC, receptacle	Switchcraft EAC-301
Q3	03-10000	1			N-Channel JFET	U1899E
Q4	03-10000	1			N-Channel JFET	U1899E
Q5	03-10007	1			NPN Transistor (TO5)	2N2102
Q6	03-10002	1			PNP Transistor (TO5)	2N4036
Q7	03-10008	1			NPN Transistor (TO3 steel)	2N3055 (steel)
Q8	03-10009	1			PNP Transistor (TO3 steel)	2N6246-8 (steel)
Q9	03-10003	1			NPN Darlington Transistor (TO92)	2N5172
R1	01-01081	1			100K 5% 1/4W Carbon Film	RC07GF104J
R2	01-01081	1			100K 5% 1/4W Carbon Film	RC07GF104J
R3	01-01081	1			100K 5% 1/4W Carbon Film	RC07GF104J

REF.DES.	STOCK #	QUANTITY			DESCRIPTION	MANUFACTURING/PURCHASING DATA
		A	T	N		
R4	01-01081	1			100K 5% 1/4W Carbon Film	RC07GF104J
R5	01-20017	1			100K 0.05% 5ppm/C Wire Wound	Goldstar GS711-100K-.05%-5PPM
R6	01-20017	1			100K 0.05% 5ppm/C Wire Wound	Goldstar GS711-100K-.05%-5PPM
R7	01-20017	1			100K 0.05% 5ppm/C Wire Wound	Goldstar GS711-100K-.05%-5PPM
R8	01-50001	1			50K End Adjust (wide)	Beckman 89XR50K
R9	01-10012	1			20K 1% 50ppm/C 1/4W Metal Film	RN60C2002F
R10	01-10012	1			20K 1% 50ppm/C 1/4W Metal Film	RN60C2002F
R11	01-01061	1			10K 5% 1/4W Carbon Film	RC07GF103J
R13	01-01043	1			1.5K 5% 1/4W Carbon Film	RC07GF152J
R14	01-01061	1			10K 5% 1/4W Carbon Film	RC07GF103J
R15	01-01025	1			200 5% 1/4W Carbon Film	RC07GF201J
R16	01-20017	1			100K 0.05% 5ppm/C Wire Wound	Goldstar GS711-100K-.05%-5PPM
R17	01-01041	1			1K 5% 1/4W Carbon Film	RC07GF102J
R19	01-01015	1			47 5% 1/4W Carbon Film	RC07GF470J
R21	01-01038	1			750 5% 1/4W Carbon Film	RC07GF751J
R22	01-01038	1			750 5% 1/4W Carbon Film	RC07GF751J
R23	01-01015	1			47 5% 1/4W Carbon Film	RC07GF470J
R24	01-01015	1			47 5% 1/4W Carbon Film	RC07GF470J
R25	01-01015	1			47 5% 1/4W Carbon Film	RC07GF470J
R26	01-01015	1			47 5% 1/4W Carbon Film	RC07GF470J
R27	01-30001	1			1 20% 8W power wire wound	Ohmite 1500 Brown Devil
R28	01-30001	1			1 20% 8W power wire wound	Ohmite 1500 Brown Devil
R29	01-30001	1			1 20% 8W power wire wound	Ohmite 1500 Brown Devil
R30	01-30001	1			1 20% 8W power wire wound	Ohmite 1500 Brown Devil
R31	01-01025	1			200 5% 1/4W Carbon Film	RC07GF201J
R32	01-01025	1			200 5% 1/4W Carbon Film	RC07GF201J
R33	01-01049	1			3K 5% 1/4W Carbon Film	RC07GF302J
R34	01-20022	1			1.01 0.1% 10ppm/C Wire Wound	Goldstar R0001 (Block)
R35	01-20025	1			9.09 0.05% 5ppm/C wire wound	Goldstar GS810-9R09-.05%-5ppm
R36	01-20029	1			90.9 0.05% 5ppm/C wire wound	Goldstar GS809-90R9-.05%-5ppm
R37	01-20012	1			897.25 0.05% 5ppm/C Wire Wound	Goldstar GS805-897R25-.05%-5PPM
R38	01-50009	1			5 Single Turn From Top	CTS 110-5ohm
R39	01-20011	1			8.9725K 0.05% 5ppm/C Wire Wound	Goldstar GS805-8.9725K-.05%-5PPM
R40	01-50010	1			50 Single Turn From Top	CTS 110-50ohm
R41	01-20010	1			89.725K 0.05% 5ppm/C Wire Wound	Goldstar GS805-89.725K-0.05%-5PPM
R42	01-50004	1			500 Single Turn	CTS X201R501
R43	01-20009	1			897.25K 0.05% 5ppm/C Wire Wound	Goldstar GS805-897.25K-.05% 5PPM
R44	01-50003	1			5K Single Turn	CTS X201R502
R45	01-01081	1			100K 5% 1/4W Carbon Film	RC07GF104J
R46	01-50012	1			10K Top Adjust	Beckman 68WR10K
R47	01-50013	1			1K Top Adjust	Beckman 68WR1K
R48	01-50014	1			100 Top Adjust	Beckman 68WR100ohm
R50	01-01021	1			100 5% 1/4W Carbon Film	RC07GF101J
R51	01-10033	1			6.34K 1% 50ppm/C 1/4W Metal Film	RN60C6341F
R52	01-10031	1			634 1% 50ppm/C 1/4W Metal Film	RN60C6340F
R53	01-10032	1			69.8 1% 50ppm/C 1/4W Metal Film	RN60C69R8F
R54	01-50014	1			100 Top Adjust	Beckman 68WR100ohm
R55	01-01061	1			10K 5% 1/4W Carbon Film	RC07GF103J
R56	01-01010	1			18 5% 1/4W Carbon Film	RC07GF180J
S1	05-03004	1			Switch,7 Station,Int-Lock,4Pole	Centralab,VS5-03004
S2	05-03003	1			Switch, DPDT, Push-Push, Red knob	Centralab 004184

REF.DES.	STOCK #	QUANTITY			DESCRIPTION	MANUFACTURING/PURCHASING DATA
		A	T	N		
S3	05-03017	1			Slide Switch,115/230V,2Pole	Switchcraft,4625LFR
T1	04-20005	1			2500 Power transformer	DWG 2500-010
XIC3	05-10057	1			Connector, round, T05, 8 pin	TRW 8-1C5
XIC4	05-10057	1			Connector, round, T05, 8 pin	TRW 8-1C5

## SECTION VIII DRAWINGS AND SCHEMATICS

---

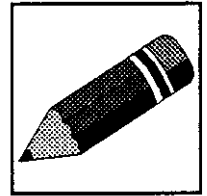

The following drawings have been included in this manual:

2500 Assembly .....	2500-600
2500 Schematic .....	2500-070

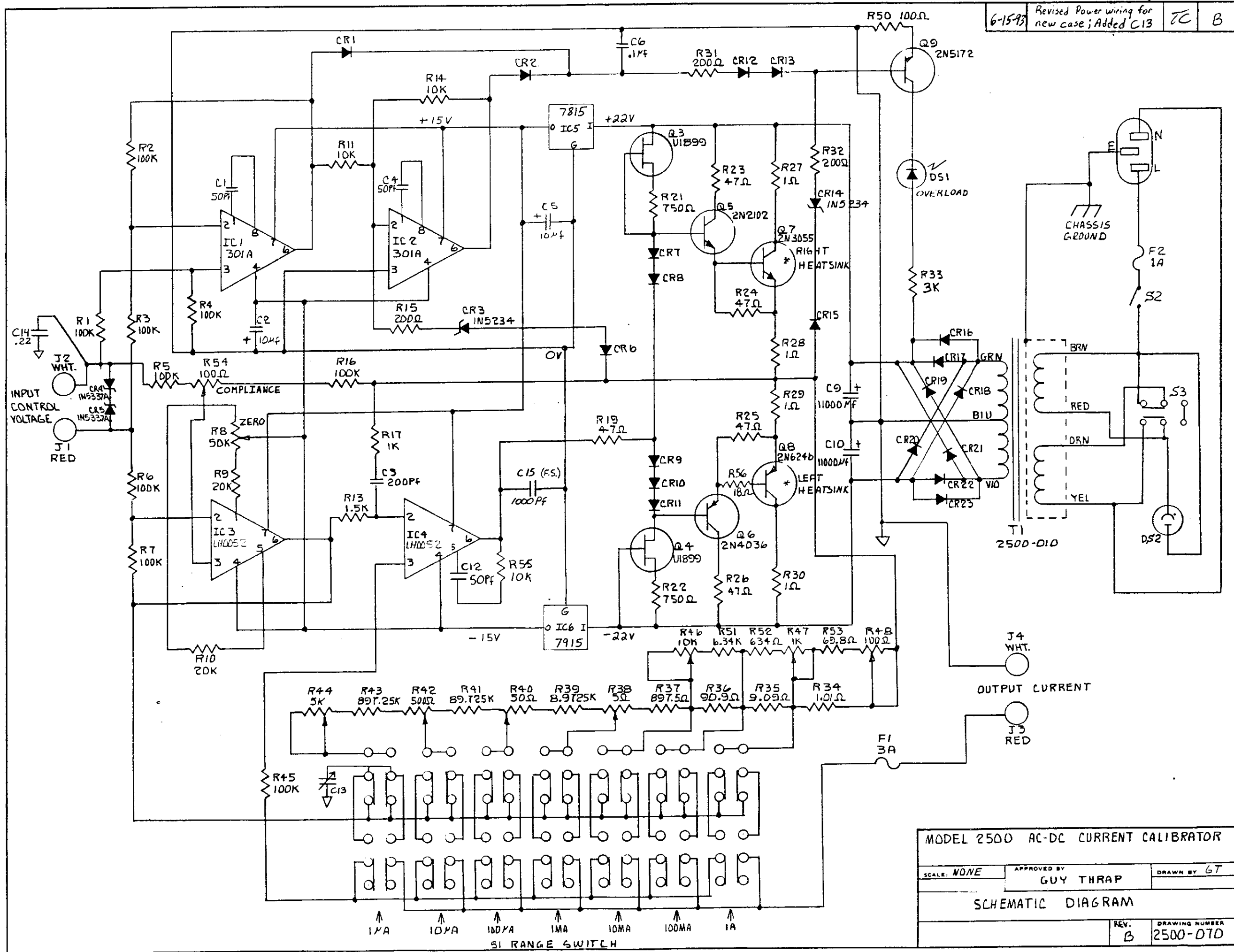

MODEL 2500 AC-DC CURRENT CALIBRATOR		
SCALE: NONE	APPROVED BY GUY THRAP	DRAWN BY GT
SCHEMATIC DIAGRAM		
REV. B	DRAWING NUMBER 2500-DTD	

