

VALHALLA SCIENTIFIC, INC.

**MODEL 4300B/4350ATE
DIGITAL MICRO-OHMMETER**

OPERATION MANUAL

**8318 MIRAMAR MALL
SAN DIEGO, CA 92121
(858) 457-5576
(858) 457-0127 Fax**

CERTIFICATION

Valhalla Scientific, Inc. certifies that this instrument was thoroughly tested and inspected and found to meet published specifications when shipped from the factory. Valhalla Scientific, Inc. further certifies that its calibration measurements are traceable to the National Institute of Standards and Technology to the extent allowed by NIST's calibration facility.

WARRANTY

The warranty period for this instrument is stated on your invoice and packing list. Please refer to these to determine appropriate warranty dates. We will repair or replace the instrument during the warranty period provided it is returned to Valhalla Scientific, Inc. freight prepaid. No other warranty is expressed or implied. We are not liable for consequential damages. Permission and a return authorization number must be obtained directly from the factory for warranty repairs. No liability will be accepted if returned without such permission. Due to continuing product refinement and due to possible parts manufacturer changes, Valhalla Scientific reserves the right to change any or all specifications without notice.

TABLE OF CONTENTS

SECTION I UNPACKING & INSTALLATION	5
1-1. INTRODUCTION.....	5
1-2. INITIAL INSPECTION.....	5
1-3. LINE VOLTAGE/FUSE SELECTION	5
1-4. INSTRUCTIONS FOR BENCH USE	6
1-5. RACK MOUNTING.....	6
1-6. SAFETY PRECAUTIONS	6
SECTION II SPECIFICATIONS.....	7
2-1. GENERAL.....	7
<i>TABLE 2-1. Ranges and Resolutions</i>	8
<i>TABLE 2-2. Environmental, Power, and Physical Requirements</i>	8
SECTION III OPTIONAL EQUIPMENT.....	9
3-1. AVAILABLE OPTIONS.....	9
3-2. TEST LEADS	10
SECTION IV MANUAL OPERATION.....	11
4-1. GENERAL.....	11
4-2. CONNECTIONS	11
<i>Figure 4-1 - Error Sources in Resistance Measurements</i>	12
4-3. SETTING VOLTAGE AND TEST CURRENT	12
4-4. CHARGING INDUCTOR MODE	12
4-5. CABLE DISCONNECT STATUS INDICATORS	13
4-6. TEMPERATURE COMPENSATION	14
SECTION V REMOTE OPERATION	15
5-1. GENERAL.....	15
5-2. THE PURPOSE OF IEEE STANDARD 488.....	15
5-3. DEFINITIONS.....	15
5-4. BUS RESTRICTIONS.....	16
5-5. DETAILED DESCRIPTIONS OF BUS OPERATIONS.....	16
5-6. SETTING THE IEEE ADDRESS	18
5-7. REMOTE AND LOCAL STATES	19
5-8. READING THE DISPLAY DATA	19
5-9. 4300B COMMAND SET FOR GPIB	20
<i>Table 5-2. 4300B IEEE Commands - Quick Reference</i>	24
SECTION VI OPTION BCD.....	25
6-1. GENERAL.....	25
6-2. BCD PIN ASSIGNMENTS.....	25
<i>Table 6-1. BCD Pin Functions</i>	26
SECTION VII THEORY OF OPERATION	27
7-1. GENERAL.....	27
7-2. GENERAL DESCRIPTION OF CIRCUITS	27
7-3. DETAILED CIRCUIT DESCRIPTIONS	28
<i>Table 7-1. A-D Converter Buffer Gains</i>	31
7-4. TROUBLESHOOTING.....	33

SECTION VIII CALIBRATION PROCEDURE.....	34
8-1. GENERAL.....	34
8-2. REQUIRED TEST EQUIPMENT.....	34
8-3. VOLTMETER CALIBRATION.....	34
8-4. CURRENT SOURCE CALIBRATION.....	35
SECTION IX SPECIAL PROCEDURES.....	37
9-1. GENERAL.....	37
9-2. CONNECTIONS AND SETTLING TIME.....	37
9-3. NOISY READINGS.....	37
9-4. DISCONNECTING THE CABLES.....	38
SECTION X MANUAL CHANGES.....	40
ADDENDUM 10-1: 4350ATE SPECIFICATIONS.....	41
SECTION XI PARTS LISTS.....	42
SECTION XII DRAWINGS AND SCHEMATICS.....	43

SECTION I UNPACKING & INSTALLATION

1-1. Introduction

The Model 4300B is a unique instrument capable of handling even the toughest resistance measurement applications. The 4300B is designed to measure the low resistance of such items as coils, transformers, ballasts, heater elements, etc. Some features of the 4300B that give it an edge over competitive products are:

- "Charging Inductor" mode for reduced settling times.
- "Disconnect Status" indicators designed with safety in mind.
- Full 4-wire Kelvin terminal configuration.
- Fully selectable test currents up to 10 amps.
- Available locking rear Bendix connectors.
- Available data outputs and remote programming capability.
- Available high-speed version for assembly lines (4350ATE).

These features and more are discussed fully in the operating instructions of this manual. **This device may be dangerous if used in a manner contrary to its design!** Please read this manual thoroughly before operating your 4300B (4350ATE).

1-2. Initial Inspection

If the shipping carton is damaged, request that the carrier's agent be present when the unit is unpacked. If the instrument appears damaged, the carrier's agent should authorize repairs before the unit is returned to the factory. Even if the instrument appears undamaged, it may have suffered internal damage in transit that may not be evident until the unit is operated or tested to verify conformance with its specifications. If the unit fails to operate or fails to meet the performance specifications of Section 2, notify the carrier's agent and the nearest Valhalla Sales Office. Retain the shipping carton for the carrier's inspection. DO NOT return equipment to Valhalla Scientific or any of its sales offices prior to obtaining authorization to do so.

1-3. Line Voltage/Fuse Selection

The only adjustments required before placing the unit in operation are to set the rear panel switch to the correct local AC line voltage and verify that the proper fuse for this voltage is installed as follows:

105 to 125 VAC = 3 Amp Slo-blo

210 to 250 VAC = 1 Amp Slo-blo

1-4. Instructions for Bench Use

The unit is supplied with all the hardware required for bench use and special instructions for use in this manner are not necessary. However, before connecting the unit to the local power source, verify that the power cord is equipped with a three-terminal connector (see the Safety Precautions of paragraph 1-6).

1-5. Rack Mounting

Optional brackets are available for mounting the Model 4300B (4350ATE) in a standard 19" equipment rack. These are listed in Section 3. The size of the unit and the location of its center of gravity dictate that it must be supported on both sides along its entire length through the use of trays or slides. If it is to be transported while mounted in a rack, it should be supported so as to prevent upward or downward movement.

It is recommended that blank panels at least 1.75 inches high be installed between this and any other units in the rack to ensure freedom of air flow. Under no circumstances should the ambient air temperature around the unit exceed 50°C while the unit is in operation or 70°C when power is removed.

1-6. Safety Precautions

The power plug must be a three-contact device and should be inserted only into a three-contact mating socket where the third contact provides a ground connection. If power is provided through an extension cable, the ground connection must be continuous. **Any discontinuity in the ground lead may render the unit unsafe for use!**

The Model 4300B (4350ATE) employs forced air cooling of the internal components. This operates continuously and care must be taken to ensure that the intake and exhaust ports remain clear. **Blocked vents may cause a dangerous overheating condition!**

SECTION II SPECIFICATIONS

2-1. General

This section contains accuracy and operational specifications for the Model 4300B. See Addendum 10-1 for the 4350ATE High-Speed Digital Micro-ohmmeter specification changes. The accuracy specifications are valid for a period of one year from the date of calibration at a temperature of 22°C to 28°C. Outside this range, the temperature coefficient specification applies.

Accuracy: $\pm 0.04\%$ of reading ± 3 digits (add ± 3 digits on 20mV range; $\pm 0.02\%$ of reading on 10A range)

Temperature Coefficient: (5°C-21°C and 29°C-50°C) $\pm 0.005\%$ of reading per °C

<u>Temperature Sensors:</u>	"AL" and "CU" add $\pm 0.05\%$ of reading to accuracy specification (Temperature compensators are accurate to $\pm 0.1\%$ of the rated coefficient)
<u>CMR Ratio:</u>	60dB at DC, 50Hz, and 60Hz
<u>Display:</u>	4½ digit (19999) Liquid Crystal Display
<u>Overload Indication:</u>	Display Flashes -1
<u>Terminal Configuration:</u>	Four-wire Kelvin
<u>Conversion Rate:</u>	Approximately 400 milliseconds
<u>Maximum Kick-Back Protection:</u>	500 Amps Peak Induced Current
<u>Compliance Voltage (Normal Mode):</u>	7.5 VDC nominal at 10A resistive
<u>Compliance Voltage (Charging Inductor Mode):</u>	> 20 VDC when indicator is lit
<u>Open Circuit Voltage (Test Current Off):</u>	< 20mV between I _{HI} and I _{LO} terminals

TABLE 2-1. Ranges and Resolutions

Resistance Ranges	Resolutions	Full Scale Voltages		
		20mV	200mV	2V
2mΩ	.0001mΩ	10A	---	---
20mΩ	0.001mΩ	1A	10A	---
200mΩ	00.01mΩ	100mA	1A	10A
2Ω/2000mΩ	.0001Ω/00.1mΩ	10mA	100mA	1A
20Ω/20000mΩ	0.001Ω/0001mΩ	1mA	10mA	100mA
200Ω	00.01Ω	100μA	1mA	10mA
2000Ω	000.1Ω	---	100μA	1mA
20000Ω	0001Ω	---	---	100μA

[-----Test Current Ranges-----]

TABLE 2-2. Environmental, Power, and Physical Requirements

<u>Environmental</u>	<p>Operating Temperature Range: 0 to 50°C</p> <p>Humidity: 70% RH at 40°C non-condensing</p> <p>Storage Temperature Range: -30°C to 70°</p>
<u>Power Requirements</u>	<p>Power Supply Voltage: 105-125 or 210-250 VAC</p> <p>Power Supply Frequency: 50 - 60 Hz</p> <p>Power Supply Consumption: 200VA Maximum</p>
<u>Physical</u>	<p>Dimensions: 17"(43cm)W x 17"(43cm)D x 4"(10cm)H</p> <p>Weight: 9.1Kg (20 lbs) NET; 11.8Kg (26 lbs) SHIPPING</p>

SECTION III OPTIONAL EQUIPMENT

3-1 Available Options

Listed below are the options available for use with the Model 4300B and 4350ATE Digital Micro-ohmmeters.

Option RX-3: Rack Ears

Option "RX-3" is a set of rack ears that permit mounting of the instrument in a standard 19" equipment rack.

Option TL-488: IEEE Interface

Option "TL-488" is an IEEE-488 GPIB Talk-Listen interface that allows control via the IEEE-488 Bus for remote range programming and resistance measurement data acquisition. See Section 5.

Options GP-1, GP-2: GPIB Cable

1 or 2 meter IEEE-488 GPIB interface cable for use with Option TL-488.

Option BCD: Data Outputs

Option "BCD" is a parallel binary-coded-decimal data interface with outputs for display and range data. See Section 6.

Model 1248: Dual-Limit Comparator

The Valhalla Model 1248 may be used in conjunction with a Model 4300B and Option BCD above. The Model 1248 is a dual-limit comparator that interprets the display indications of the 4300B as either "HI", "LO" or "GO", based on a window that is set by the user. Relay contact closure is provided to trigger an alarm, batch sorter, counter or other device. The mating cable from the 4300B to the 1248 is 2½ feet in length and designated as "IDC-3".

Option IDC-3: BCD Interface Cable

Option IDC-3 is an interface cable designed specifically to connect the 4300B BCD output to the inputs of the Model 1248 BCD Comparator.

It is 2½ feet in length and is terminated on one end in a 50 pin Amphenol connector with wire break-outs, and on the other end in a 24 pin Amphenol connector that mates with the BCD output port of the 4300B. See drawing number 4300-051 at the back of this manual.

Options RS232 and PAR: Interfaces

The ohmmeter is now available with optional serial and/or printer interfaces. The serial interface is designed to be compatible with RS232C systems. This interface may be used for remote data acquisition only, and does not allow mode or range control. The printer interface is compatible with Centronics parallel printers, and may be configured to print raw data or labels.

If either of these options has been installed, please refer to Section 10 for operating instructions.

Options AL and CU: Compensators

Option "AL" is a compensating temperature sensor for aluminum (4030 ppm/°C) providing a 20 °C or 25 °C reference.

Option "CU" is a compensating temperature sensor for copper (3931 ppm/°C) providing a 20 °C or 25 °C reference.

Option CK: Extension Cable

Option "CK" is a 4' shielded extender cable that permits the placement of compensators in closer proximity to the resistor under test.

3-2. Test Leads

Option K: General-Purpose Lead Set

Option "K" is a shielded, 4-wire Kelvin cable set, forty-eight inches in length terminated in "KCS" gold-plated clips.

Option KCS: Gold-Plated Clips

Option "KCS" is a light-weight, gold-plated Kelvin clip set for 4-wire measurements on smaller components and leads. Clips open to 1/2 inch and accommodate test currents of up to 10 amperes.

Option KK: Heavy-Duty Cable Set

Option "KK" is a heavy-duty 4-wire Kelvin cable set, 48-inches in length terminated in "JAWS" clamps for connecting to large motors, bushings, etc. Opening is 2". A variation of this cable set is Option "KL" which is 10 feet in length.

Option JAWS: Heavy-Duty Clamps

Option "JAWS" are the heavy-duty clamps used to terminate Option "KK".

Option MP-1: Kelvin Micro-Probes

Option "MP-1" is a 48-inch shielded Kelvin 4-wire cable set with a 1-ampere test current capacity employing a set of Kelvin Micro-Probes. The probes are equipped with stainless steel V-1 tips separated by 0.05 inches.

Option MP-2: Kelvin Mini-Probes

Option "MP-2" is a 48-inch shielded 4-wire cable set equipped with Kelvin Mini-Probes having spring loaded stainless steel tips. The V-1 tips are separated by 0.18 inches. Test current capacity is 10 amperes.

Option MP-4/MP-5: Surface Probes

These probes permit rapid, repeatable bonding testing on a variety of screened or flat surfaces. Test current is evenly distributed through the probe base while sensing is accomplished via a spring loaded center contact. The MP-4 target area is 1" in diameter. The MP-5 target area is .4" in diameter. The current capacity of both probes is 10 amperes.

Option JB-2: Rear Bendix Connectors

Option "JB-2" is a set of rear-mounted positive-mating locking Bendix style connectors. The mating cable set is Option "KC". See drawing number 4300-407 at the back of this manual.

Option KC: Bendix Cable Set

Option "KC" is a heavy-duty 4-wire Bendix style lead set. Option KC must be used with Option JB-2 above.

Option BBL: Banana-to-Banana Cable

Option "BBL" is a 48" shielded cable terminated in dual banana plugs. This cable may be used for voltage and current connections to the ohmmeter.

Option SL-48: Low-Thermal Leads

Option "SL-48" is a 48" shielded lead set terminated in gold-plated spade lugs. This lead set is designed to eliminate problems caused by thermal EMF's and is rated for the maximum output current of the instrument.

Option C: Banana-to-Clip Cable

Option "C" is a 48" general-purpose shielded lead set terminated on one end in a dual banana plug and on the other end in red and black copper alligator clips.

SECTION IV MANUAL OPERATION

4-1. General

This section of the manual contains complete instructions for manually operating the 4300B Digital Micro-Ohmmeter.

4-2. Connections

Connections to the 4300B are made via 4 heavy-duty binding posts on the front panel. When using Valhalla test leads, the tabbed side of each banana jack is connected to the **current** terminals (see below). This ensures that current is carried in the largest conductor of the cable, and that the voltage input is shielded. A set of rear mounted terminals is available as Option JB-2.

V_{HI} ☉ ☉ I_{HI} ←Tab

V_{LO} ☉ ☉ I_{LO} ←Tab

NOTE: If the input terminals are not connected to a load (open), the display will roll around and may or may not indicate an overrange. This is a characteristic of the voltmeter and does not indicate a fault in the instrument.

The four-terminal configuration of the 4300B eliminates errors normally caused by test lead and contact resistances. In many applications the contact resistance can exceed the value of the load by several orders of magnitude. The 4300B bypasses this potential error source by providing two terminals of constant current and an additional two terminals for high impedance voltage measurement. The result is a fast, accurate resistance measurement of the load, independent of the resistance of the current carrying leads.

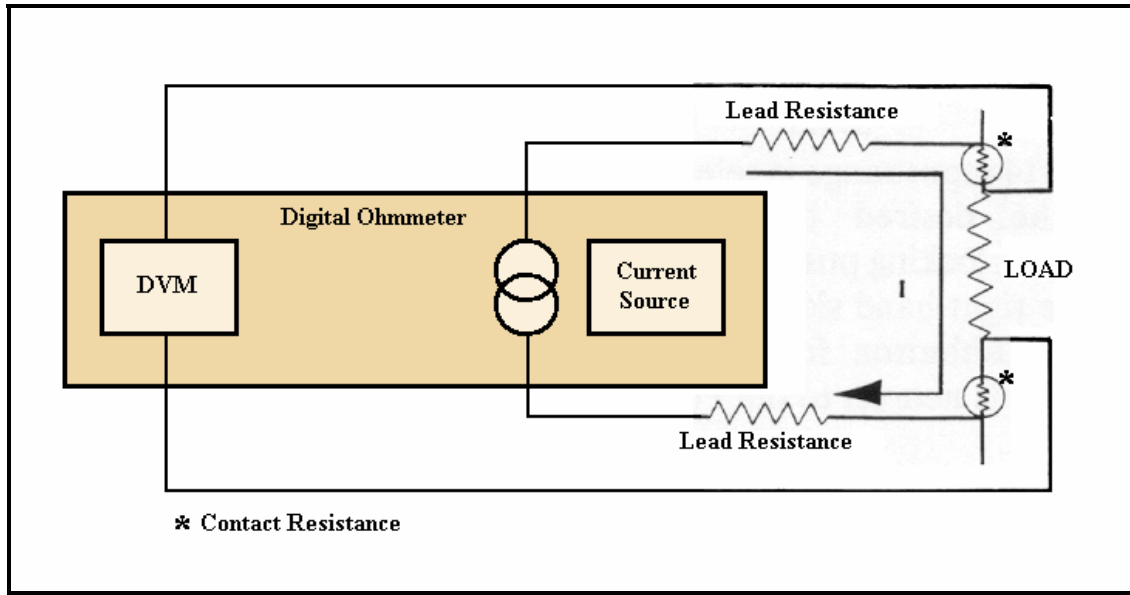

Figure 4-1 - Error Sources in Resistance Measurements

Figure 4-1 illustrates how the 4-wire principle is used to eliminate lead, wire and contact resistances as potential error sources. The internal current source inherently overcomes all series resistance (within compliance voltage limits) and delivers a precise constant current. The internal high-impedance DVM senses the voltage drop across the load. There is negligible contact and lead resistance error created by the voltage measurement because the high input impedance of the DVM limits current flow in the voltage leads.

4-3. *Setting Voltage and Test Current*

The Full Scale Voltage is selected via three interlocking push-buttons. Three LED's directly above the push-buttons indicate which range has been selected. The Test Current is selected via a six-position rotary switch. Six LED's mounted to the left of the switch determine the resistance range that will be displayed as indicated by the front panel matrix. The resistance range is found on the matrix at the intersection of the Voltage Range and Current Range LED's.

The test current may be turned off and on via the front panel Test Current switch, by a command from the IEEE interface board, or by a remote switch using Option "RS" as described in Section 3. An LED positioned directly above the Test Current switch indicates the status of the current source.

4-4. *Charging Inductor Mode*

The Charging Inductor mode LED indicates when the standard current source compliance voltage of 7 volts is exceeded. In this situation the 4300B provides a booster shot in excess of 20V to reduce the settling time when a large inductive load is being measured. The display readings should be ignored when this LED is illuminated.

4-5. Cable Disconnect Status Indicators

The SAFE and UNSAFE LED's indicate whether or not it is safe to disconnect the test leads from the load. When a highly inductive load is being measured, a potentially lethal back-EMF is induced when the test current is removed. The 4300B provides a discharge path for this back-EMF and monitors the voltage. The SAFE LED is illuminated when the back-EMF is less than five volts.

CAUTION: Although the 4300B is protected against up to 500 Amps of inductive kickback, it is not advisable to remove test leads with the Test Current On, or with the UNSAFE LED lit. In some extreme applications if leads are removed or pull loose before the SAFE LED is lit, damage may occur to the 4300B and/or injury to the operator!

The UNSAFE LED is also illuminated whenever a test current of .1A or greater is selected and the Test Current is turned On, regardless of the load.

4-6. Temperature Compensation

Automatic Temperature Compensation (ATC) simulates a constant ambient temperature chamber for materials which are normally subject to varying ambient temperatures. When the ATC mode is selected, the temperature sensor (Options "AL" and "CU") automatically senses the ambient temperature and compensates the reading to indicate what the actual resistance value would be in a controlled 20°C or 25°C environment.

The ATC mode is selected by pressing the Temperature Compensation On push- button. An LED positioned directly above this push-button indicates that this mode has been selected. The temperature sensors are connected to the 4300B via the front panel BNC connector. The temperature sensor may be extended with an Option "CK" compensator extension cable. The FAULT indicator is illuminated when the ATC mode is selected if the temperature sensor connections are not intact.

CAUTION: The housing of the compensator is electrically connected to the internal circuitry of the instrument (ground), and to the V_{LO} terminal. Care must be taken so that the housing does not contact live circuitry.

SECTION V REMOTE OPERATION

5-1. *General*

This section of the manual contains instructions for operating the 4300B via the GPIB (IEEE-488) interface. For information regarding operation using the RS232C serial or Centronics parallel interface, refer to Section 10. Throughout this section it is assumed that the reader is already familiar with manual operation of the 4300B as described in Section 4.

5-2. *The Purpose of IEEE Standard 488*

The purpose of the standard is to allow for interconnection of programmable instruments with a minimum of engineering. The intent is to remove the need for adapters and the numerous types of patching cables often encountered with other forms of interfaces. The IEEE-488 standard defines a system configuration for programmable instruments such as calculators, voltmeters and other types of peripheral devices produced by various manufacturers. It provides a set of rules for establishing a defined communications link with a high degree of compatibility yet maintaining flexibility between independently manufactured products.

5-3. *Definitions*

Listed below are definitions of the terms used to describe the IEEE-488 interface:

Bus: A data link which is usually a set of several parallel wires within a multi-wire cable.

Bi-Directional Bus: A "highway" used for two-way communication, with input and output data being carried on the same lines.

Bit-Parallel: A data transmission method in which all of the bits composing an item of data are present simultaneously on a group of wires in a bus.

Byte: A group of eight data bits which is treated as a single item of data.

Byte-Serial: A data transmission method in which information, in bit-parallel bytes, is transferred sequentially between devices.

Device Dependent Message: A message containing commands or data intended for a specific device.

Handshake: An exchange of signals between two devices which is used to control the transfer of data between them.

Interface: The part of an instrument or system which enables it to be connected to another via a bus.

Interface Message: A message intended for interface management.

Local Operation: Operation of a device by its front panel controls (also referred to as Manual Control).

Remote Operation: Operation of device under the control of another via the bus.

5-4. Bus Restrictions

The IEEE-488 Interfacing Standard (also known as IEC DTC66 (WG3), ANSI MC1-1, GPIB, HP-IB, etc.), defines a bidirectional bus for interconnecting programmable instrumentation in a bit-parallel, byte-serial fashion. It defines limitations as follows:

1. A maximum of 15 devices may be interconnected by a single bus.
2. The total bus length may not exceed 20 meters, with a maximum interconnection length of 4 meters.
3. Maximum transmission rate is 1 megabyte per second.
4. All bus data is digital.

Of the devices on the bus, only *one* may be the controller which exercises control over all other devices, and is also capable of operating as a talker or listener. The other devices may be listeners (only able to receive data) or talkers (only able to send data), or both. The model 4300B is capable of talking and listening. The controller may address other devices and command them to listen or talk. Only one device may talk at any one time.

The interconnecting cable consists of sixteen signal wires and eight ground returns linking devices into a complete system:

1. Eight data wires (DIO-0 thru DIO-7)
2. Five management wires (ATN, EOI, SRQ, IFC, and REN)
3. Three "handshake" wires (DAV, NRFD and NDAC)

Each cable connector is a plug/socket combination to permit "daisy-chaining" of units. It should be noted that these wires use "inverse logic". That is to say that a low level indicates the true (asserted) state and a high level indicates a false (non-asserted) state.

5-5. Detailed Descriptions of Bus Operations

The five management wires are described as follows:

ATN: Asserted by the controller whenever an address or a command is present on the bus.

EOI: May be asserted by the controller or any talker. With ATN true, EOI indicates that the controller is polling devices. With ATN false, EOI is asserted by the talker to indicate the end of data.

SRQ: May be asserted by any device. This indicates that the device requires attention (e.g., a fault has occurred). Normally, the controller will respond by polling to determine which device requires service.

IFC: May be asserted only by the controller. This line initializes the bus to a reset state.

REN: May be asserted only by the controller. This signal places the addressed device into the remote mode.

The three handshake wires are described as follows:

DAV: May be asserted by any talker; indicates that a valid data byte is present on the data wires.

NRFD: May be asserted by any listener. Indicates that the listener is not ready to receive data.

NDAC: May be asserted by any listener. Indicates that the listener has not yet finished reading the data byte.

The transfer of data on the bus is controlled by these three handshake wires. It is important to note that the drivers for the handshake wires are all connected for wired-on operation. That is, as long as any of the devices on the bus asserts a handshake line, it will remain true. There must be a complete consensus among the devices for any handshake wire to be high (false).

The talker first waits for all devices to be ready to accept data (checks that NRFD is false) then puts one byte of data on the bus and asserts DAV. It waits for all devices to indicate that the data has been accepted (that is, NDAC to become false) before starting to transfer the next byte of data. This handshake protocol assures that data on the bus is transferred at the speed of the slowest device on the bus.

Data is sent in 8-bit bytes on the DIO wires, usually (as in the 4300B) using the ISO-7 standard ASCII characters. Table 5-1 lists each ASCII character and the bus messages applicable to each.

ISO BIT & DIO LINE NUMBER	0		1		2		3		4		5		6		7		COLUMN
	7	6	5	4	3	2	1	0	7	6	5	4	3	2	1	0	
0 0 0 0	NUL		DEL		SP	00	0	16	@	00	P	16	.		p		0
0 0 0 1	SOH	GTI	DC 1	LLO	!	01	1	17	A	01	Q	17	a		q		1
0 0 1 0	STX		DC 2		"	02	2	18	B	02	R	18	b		r		2
0 0 1 1	ETX		DC 3		#	03	3	19	C	03	S	19	c		s		3
0 1 0 0	EOT	SDC	DC 4	DCI	\$	04	4	20	D	04	T	20	d		t		4
0 1 0 1	ENQ	PCC ¹	NAK	PPU	%	05	5	21	E	05	U	21	e		u		5
0 1 1 0	ACK		SYN		&	06	6	22	F	06	V	22	f		v		6
0 1 1 1	BEL		ETB		'	07	7	23	G	07	W	23	g		w		7
1 0 0 0	BS	GET	CAN	SPE	(08	8	24	H	08	X	24	h		x		8
1 0 0 1	HT	TCT	EM	SPD)	09	9	25	I	09	Y	25	i		y		9
1 0 1 0	LF		SUB		*	10	:	26	J	10	Z	26	j		z		10
1 0 1 1	VT		ESC		+	11	;	27	K	11	[27	k		{		11
1 1 0 0	FF		FS		,	12	<	28	L	12	\	28	l				12
1 1 0 1	CR		GS		-	13	=	29	M	13]	29	m		}		13
1 1 1 0	SO		RS		.	14	>	30	N	14	^	30	n		~		14
1 1 1 1	SI		US		/	15	?	UNL	O	15	_	UNT	o		DEL		15
		ADDRESSED COMMAND GROUP (ACG)		UNIVERSAL COMMAND GROUP (UCG)		LISTEN ADDRESS GROUP (LAG) PRIMARY COMMAND GROUP (PCG)				TALK ADDRESS GROUP (TAG)				SECONDARY COMMAND GROUP (SCG)			

¹Requires Secondary Command

Table 5-1 ASCII Character Codes

Notes: 1 Device Address messages shown in decimal

2 Message codes are:

- | | | | | | |
|-----|----------------|-----|---------------------------|-----|-----------------------|
| DCI | Device Clear | LLO | Local Lockout | SDC | Selected Device Clear |
| GET | Device Trigger | PPC | Parallel Poll Configure | SPD | Serial Poll Disable |
| GTI | Go to Local | PPU | Parallel Poll Unconfigure | SPE | Serial Port Enable |

Note that the table is divided into two main groups; the primary command group and the secondary command group. The secondary command group is not utilized in the 4300B.

The primary command group is further divided into four subgroups as follows:

1. **Addressed Command Group** - applied only to addressed devices.
2. **Universal Command Group** - applied to all devices.
3. **Listen Address Group** - set of device listen addresses.
4. **Talk Address Group** - set of device talk addresses.

Data in the above command groups is sent with ATN "true". These type of commands are understood by all devices using the IEEE-488 standard. When data is sent with ATN "false", it is referred to as a *device dependent* command. A device dependent command is specific to a particular device, and may or may not be understood by other devices.

5-6. *Setting the IEEE Address*

The IEEE "address" is the method by which the system controller distinguishes one device on the bus from another. The address of the 4300B is determined by the setting of a binary-weighted switch on the rear of the instrument. An example of setting the switches to address "12" is shown below:

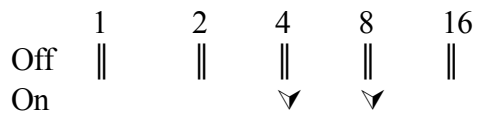

In this case, $8 + 4 = 12$. In another example, the $16 + 8 + 1$ switches would be enabled to set the address to 25.

The address you choose is entirely dependent on your application and by the type and quantity of devices on your IEEE bus. Some guidelines to follow are:

- 1) Each device on the bus must have its own unique address. Operating two devices at the same address will produce undefined results and is not recommended.
- 2) Avoid setting the 4300B to address 0 (all switches off) or to address 31 (all switches on) as this may interfere with the system controller.
- 3) If the setting of the switches is changed, power must be cycled in order to place the new address into memory.

☞ In all future examples, the 4300B is assumed to have its address set to "12".

5-7. *Remote and Local States*

➤ **Local State**

When the 4300B is in the "local" state the REMOTE indicator on the front panel is extinguished and full manual control as described in Section 4 may be performed. The user should also note that the 4300B will ignore commands from the GPIB while in the local state.

The 4300B automatically powers-up in the local state. Other methods for placing it in the local state are by cycling power or by sending a *return to local* (RTL) command over the bus. This is done in HP Basic using the command: **LOCAL 712**

To ensure compatibility with all controllers, the 4300B may also be returned to the local state by sending it the code: **L**

➤ **Remote State**

In this state the REMOTE indicator on the front panel is illuminated and all controls on the front panel are disabled except the power switch.

The remote state may only be entered via the bus. If the 4300B receives its listen address while the REN line is asserted, it will enter the remote state. Placing the instrument into remote is an easy way of verifying that all connections and address selections have been done properly. This may be accomplished in HP Basic using the command: **REMOTE 712** The 4300B should enter the remote state and illuminate the REMOTE indicator. Verify that no other device on the bus was affected by execution of this command.

5-8. *Reading the Display Data*

The resistance data on the 4300B's display is always available to be read by the system controller. The 4300B does not require that a query or any other command be issued in order to retrieve it. Also, the 4300B does not need to be in REMOTE in order for the display to be read. Retrieving the data will clear the reading buffer. The controller must then wait until the next update of the A-to-D converter before a new value becomes available. Data may be read at the rate of 2½ readings per second for a 4300B, or 12½ readings per second for a 4350ATE.

The fact that the readings are always available simplifies measurement retrieval. Every time the system controller polls the 4300B's address, an instantaneous resistance value is returned corresponding to the displayed value.

The following program shows an example of retrieving a resistance measurement from the 4300B. The program is written in HP Basic. If you are using a programming language or package other than HP Basic, consult your Programmer's Manual for the correct command syntax. The 4300B is assumed to be at address 12.

```
10 ENTER 712;A$
20 PRINT A$
30 GOTO 10
40 END
```

The execution of this program results in a continuous display of the resistance measurement, updated at the conversion rate of the instrument's A-to-D converter.

The result is returned in scientific notation, in ohms. As an example, assume that the 4300B is in the 2V and .1mA ranges and the front panel display indicates "10567" which is 10,567 ohms. The program above is executed.

The 4300B responds with the following number (contained in A\$):

+1.0567E+4

This is the measurement in scientific notation, in ohms. The "E" signifies a power of 10^4 , or 10000. This means that the significant digits of the response should be multiplied by 10000.

In another example, assume that the 4300B is in the 20mV and 10A ranges, and the front panel display indicates "1.9095" which is equal to 1.9095 milliohms. The program is executed.

The 4300B responds with the following number (contained in A\$):

+1.9095E-3

This is the measurement in scientific notation, in ohms. The "E" signifies a power of 10^{-3} , or 0.001. This means that the significant digits of the response should be multiplied by 0.001.

☞ An over-range condition is indicated by:

+2.0000E±?

Each response is terminated with an "output data terminator" which is used to signal the end of the transmission to the controller. The default terminator is a $C_{R}L_{F}$ (carriage-return and line-feed). The terminator may be changed using the "D" command. Refer to section 5-9-4.

5-9. 4300B Command Set for GPIB

This section contains a description of all commands that are recognized by the 4300B using its IEEE-488 interface (Option TL-488). As noted in section 5-8, the 4300B does not need to be queried in order to retrieve the measured resistance data. The commands listed in this section are used to set ranges, turn the test current on and off, and to setup internal communication protocol.

☞ A condensed listing of the 4300B command set is given in Table 5-2.

When sending commands to the 4300B, an "input data terminator" must be used to signal the end of the command line. The 4300B recognizes a $_$ (carriage-return) or EOI asserted with the last character as valid input terminators.

Commands must be sent using upper case characters. Multiple commands may be sent on the same line provided that they are separated by a comma (,).

The following program shows an example of setting the ranges of the 4300B. The program is written in HP Basic. If you are using a programming language or package other than HP Basic, consult your Programmer's Manual for the correct command syntax. The 4300B is assumed to be at address 12.

```
10 REMOTE 712
20 OUTPUT 712;"V2,I3,C1"
30 WAIT 2
40 ENTER 712;A$
50 PRINT A$
60 LOCAL 712
70 END
```

The result of this program is to set the 4300B to the 2V, 100mA ranges and turn on the test current. The controller waits for 2 seconds (for settling), then retrieves the measured value. The 4300B is then returned to local mode.

5-9-1. Voltage Range

The "V" command is used to set the full scale voltage range of the internal voltmeter. The 4300B interprets this command as follows:

V0 Selects the 20mV range
V1 Selects the 200mV range
V2 Selects the 2V range

5-9-2 Test Current Range

The "I" command sets the value of test current that will be used to make the resistance measurement. The 4300B interprets this command as follows:

I0 Selects .1mA
I1 Selects 1mA
I2 Selects 10mA
I3 Selects .1A
I4 Selects 1A
I5 Selects 10A

5-9-3. SRQ's and Serial Polls

The IEEE-488 bus incorporates a serial line that may be used by a device on the bus to alert the controller if problems are encountered or if it requires attention. This method draws attention to a device without disrupting normal bus operation. The controller may then choose to ignore or act upon the request.

The "SRQ" or "service request" line may be asserted to alert the controller. The 4300B may be setup using the "Q" command to assert SRQ if the controller sends data to it that is not decodeable by the 4300B.

Q0 4300B will not assert SRQ (default)
Q1 4300B will assert SRQ if it receives a command that it does not understand

If the SRQ line is asserted, the controller should then perform a serial poll to determine which device requires service. The 4300B will return an ASCII zero (0) in response to a serial poll if it did not generate the SRQ. A non-zero number will be returned if it was responsible for asserting SRQ. A serial poll is performed in HP Basic using the command: **SPOLL(712)** which would poll the device at address 12.

5-9-4. Output Data Terminator

The "D" command determines the type and quantity of terminators that will be used to signal the end of any data that the 4300B returns to the controller. This includes measured resistance data as well as the response to the "configuration status" query. The 4300B interprets this command as follows:

D0	$\begin{matrix} C & L \\ R & F \end{matrix}$ (default)
D1	$\begin{matrix} C & L \\ R & F \end{matrix}$ with EOI asserted
D2	$\begin{matrix} C & L \\ R & F \end{matrix}$
D3	$\begin{matrix} C & L \\ R & F \end{matrix}$ with EOI asserted

☞ The D1 selection is preferred by IEEE-488.2 systems such as National Instruments®.

5-9-5. Test Current Control

The "C" command is used to enable or disable the output of the current source. This command is decoded as follows:

C0 Turns the test current off
C1 Turns the test current on

5-9-6. Display Hold

The display of the 4300B may be frozen from the GPIB bus using the commands listed below. While in the "hold" mode the A-to-D converter is still performing measurements, but the results are not sent to the 4300B's display or to the IEEE output buffer. Therefore once a trigger is sent or tracking is resumed, the display will instantly reflect the latest measurement. The 4300B interprets these commands as follows:

T selects continuous tracking mode (default)
S selects hold mode; also used to trigger a single reading while in the hold mode

5-9-7. Temperature Compensation

The automatic temperature compensation (ATC) feature of the 4300B may be enabled or disabled from the GPIB. If ATC mode is enabled the readings are automatically adjusted by the temperature sensor attached to the front of the 4300B (refer to Section 4-6).

- N selects normal mode; ATC off
- A selects ATC on

5-9-8. Configuration Status Query

This advanced command may be used to verify the results of sending the commands mentioned previously. It may also be used to check for faults in the ATC system or to check the present setting of the manual controls on the front panel. The charge and discharge of inductive loads may be monitored to determine when valid readings are available and also to check the cable disconnect status indicators.

Upon receiving the code **E** the 4300B will place into its output buffer a "configuration status word". The status word is made available for the next read by the controller. No measurement data is available until this word is read. The word is in the format:

Q?V?I?SND?C?UHF

where

- Q? reflects the present value of the SRQ command
- V? reflects the present voltage range setting
- I? reflects the present test current setting
- S is the letter "S" if hold mode has been selected, or "T" if tracking mode is selected
- N is the letter "N" if normal mode has been selected or "A" if ATC is enabled
- D? reflects the present value of the output data terminator command
- C? reflects the test current status
- U is the letter "U" if the 4300B senses that it is UNSAFE to disconnect cables; an ASCII space character indicates SAFE
- H is the letter "H" if the 4300B's charging inductor mode has been activated; an ASCII space character indicates no charging inductor
- F is the letter "F" if a fault is detected in the ATC sensing mode; an ASCII space character indicates no faults

ASCII CODE:		V _X	I _X	Q _X	D _X	C _X
X=	0	20mV	0.1mA	No SRQ	C _R L _F	Test Current OFF
	1	200mV	1mA	SRQ on Input Error	C _R L _F w/ EOI	Test Current ON
	2	2V	10mA		C _R	
	3		100mA		C _R w/ EOI	
	4		1A			
	5		10A			

S Selects hold mode / Triggers single reading

T Selects continuous reading mode

N Selects normal mode (ATC off)

A Selects ATC mode On

L Returns 4300B to Local

E Configuration Status Word Query
(Q?V?I?SND?C?UHF)

Table 5-2. 4300B IEEE Commands - Quick Reference

SECTION VI OPTION BCD

6-1. General

Option "BCD" provides parallel Binary Coded Decimal data output that corresponds to the display indication. Signals are also provided for range information, overload, and end of conversion (EOC). A run/hold line is also provided to halt the 4300B A-to-D converter (voltmeter). Also refer to drawings 4300-079 and 4300-609. The signals are TTL compatible ($0 \leq .8V$, and $1 \geq 2.4V$) and will drive 1 LS TTL load.

6-2. BCD Pin Assignments

Pins 1 to 17 - DATA

This is the BCD coded data which is identical to that being displayed by the 4300B.

Pin 18 - OVERLOAD

This is a logic 1 when the data on the lines above is an overload indication. (Note: The Data is arbitrary during this condition.)

Pins 19 to 21 - RANGE

This is a BCD exponent which indicates the present resistance range as follows:

Range	Pin #:				Where:
	19	20	21	R	
20000 Ω	1	1	1	7	$1 \geq 2.4V$
2000 Ω	0	1	1	6	
200 Ω	1	0	1	5	$0 \leq 0.8V$
20 Ω /20000 m Ω	0	0	1	4	
2 Ω /2000 m Ω	1	1	0	3	
200 m Ω	0	1	0	2	
20 m Ω	1	0	0	1	
2 m Ω	0	0	0	0	

Pin 22 - END OF CONVERSION (EOC)

A logic 1 signal indicates that a measurement is in progress. Note that the Data (pins 1 to 17) is not valid until 10 milliseconds after the high-to-low transition of this signal.

Pin 23 - RUN/HOLD

A logic 1 (or open circuit) on this pin enables the unit to perform continuous measurements. When this line is taken low, the unit completes the measurement in progress and halts. A pulse of 300nS will initiate a further measurement.

Pin 24 - 0 VOLTS

All signals are referenced to this pin. If it is inconvenient to use this pin as the common, the V_{LO} terminal may be used instead.

The mating connector for the BCD option is a 24-pin Male Amphenol 57 series connector, Valhalla Stock #05-10248. When using these outputs with a Valhalla Model 1248 Dual-Limit Comparator, use the IDC-3 cable for making connections.

The BCD connector pin functions are summarized in Table 6-1.

Table 6-1. BCD Pin Functions

Pin #	Function		Pin #	Function
1	1		13	1000
2	2		14	2000
3	4		15	4000
4	8		16	8000
5	10		17	10000
6	20		18	OVERLOAD
7	40		19	Range (1)
8	80		20	Range (2)
9	100		21	Range (4)
10	200		22	End of Conversion
11	400		23	Run/Hold
12	800		24	Common (0Volts)

SECTION VII THEORY OF OPERATION

7-1. General

The information contained in this section describes the theory of operation behind the Valhalla Model 4300B Digital Micro-Ohmmeter. The theory is divided into two sections. The first is a general description referring to the block diagrams of Figures 7-1 and 7-2. The second section is a detailed description referring to the schematics and diagrams at the back of this manual.

7-2. General Description of Circuits

This section describes the general function of each section of the Model 4300B. The paragraph titles used in this section refer to the block diagrams of Figures 7-1 and 7-2. "I" designates Figure 7-1 and "V" designates Figure 7-2.

7-2-1. Reference (I)

The current source reference voltage is provided by an internally ovened zener reference and its associated components. The reference circuit provides a 1.0000 volt output to the error amplifier circuit.

7-2-2. Error Amplifier (I)

The error amplifier compares the reference voltage with the signal from the range switching circuit to drive the output stage. The ON/OFF signal from the control logic commands the error amplifier to turn on or off the output stage.

7-2-3. Output Stage

The output stage provides current gain capable of driving +10 amps into the unknown resistance. The ON/OFF signal from the control logic disables the current source output when the test current is turned off.

7-2-4. Range Switching (I)

The range switching circuits provide six ranges of precision current shunts to control the output current. The current shunt values are selected so that 1 volt is dropped across the shunt for each current range (e.g. 10A in, 1V out; 1A in, 1V out; etc.). The operation of the current source is as follows: Current from the power supply flows through the load, output stage and current shunt. The voltage dropped across the shunt is compared to the reference voltage by the error amplifier. The error amplifier uses the voltage drop across the internal shunt to control the amount of current passing through the load as necessary to maintain a precise constant current.

7-2-5. Protection Circuitry (I)

The protection circuitry protects the output stage from inductive kickback voltages. The UNSAFE signal indicates the presence of back EMF from the load. See 4-5. A Metal Oxide Varistor (MOV) at the voltage input terminals protects the A to D converter by clamping any voltage in excess of 35V.

7-2-6. Power Supply (I)

The power supply provides the two available operating voltages for the current source. The output voltage is controlled by the comparator which automatically raises the compliance voltage when charging large inductors.

7-2-7. Comparator (I)

The comparator is used to detect if the error amplifier is against its end stop, indicating that the current source is charging an inductor. When an inductor is being charged, the comparator commands the power supply to output a higher voltage to reduce the ohmmeter settling time.

7-2-8. A-D Converter/Clock (V)

The analog to digital converter (A-D) measures the voltage drop across the load and converts the value into multiplexed BCD data. The A-D converter is a dual slope type. The clock oscillator supplies the necessary timing signals for the A-D converter. The A-D converter range is controlled via the control logic.

7-2-9. Reference Generator (V)

The Reference Generator provides one of three reference voltages for the A-D converter. When the ATC mode is selected, the temperature sensor (Option "AL" or "CU") compensates the Reference Generator output. The Reference Generator is controlled via the Control Logic.

7-2-10. Liquid Crystal Display/Driver (V)

The LCD Driver demultiplexes the BCD data from the A-D converter and provides the necessary signal conditioning to drive the liquid crystal display. The decimal point position is controlled via the Control Logic.

7-2-11. Front Panel Controls (V)

The Control Logic provides an interface between the front panel controls, displays, and the range circuitry of the 4300B. The Control Logic disables the front panel controls when the Option "TL-488" is fitted and the Remote LED is illuminated.

7-2-12. Power Supply (V)

The power supply provides the necessary operating voltages required by the Control Logic, A-D converter, displays and indicators.

7-3. Detailed Circuit Descriptions

This section describes in detail the operation of the main circuits of the Model 4300B. The reference designators used in this section refer to the drawings included at the back of this manual.

7-3-1 Current Source

The operation of the Current Source is described in the following paragraphs. All components in this section can be found on Schematic 4300-072 Sheet 1.

7-3-1-1. Reference

IC103 along with resistors R116-R118 and RV101 form a temperature-stabilized voltage reference. IC103 is a precision 6.95 volt ovened zener diode. The zener current is limited by resistor R116. A voltage divider composed of R117, RV101 and R118 divide the zener voltage down to 1.0000 VDC. Capacitor C103 removes any noise riding on the reference output.

7-3-1-2. Error Amplifier

The error amplifier is composed of C102, IC101A, R104, R103, RLB-2 and TR103. IC101A provides high DC gain to drive transistor TR103 via resistors R104 and R103. C102 provides local AC feedback around IC101A for stability. TR103 provides base current to the output stage. Relay contact RLB-2 is closed when the test current is turned off which removes the gate drive to TR103.

7-3-1-3. Output Stage

The output stage, composed of TR101, TR102, R101, R102, R126 and RLB-1 provides current gain capable of sourcing 10 amps. Base drive for transistors TR101 and TR102 is provided by the error amplifier. Resistors R101 and R102 equalize the emitter currents in the two output devices. Relay contact RLB-1 is closed when the test current is turned off, which connects resistor R126 across the output terminals to reduce the output voltage to less than 20mV.

7-3-1-4. Range Switching

Range selection is accomplished by selecting one of the precision current shunts R105, R107, R109, R111, R113 or R115. Relays RLC thru RLH select the appropriate combination of shunts. Only one range relay is ever energized at any one time. Resistors R106, R108, R110, R112, and R114 along with potentiometers RV102 through RV105 are used to trim the shunts to produce a precise current output.

7-3-1-5. Protection Circuitry

The protection circuitry is composed of diodes D101, D102, opto-isolator IC102-A, R123 and R124. The two diodes provide a discharge path for inductive loads. D102 conducts when the back EMF from the load is greater than 5 volts which turns on the opto-coupler through R123 and R124. This circuitry is used to determine the Disconnect Status LED condition. A Metal Oxide Varistor (MOV) installed across the voltage input terminals is used to protect the A-D converter by clamping voltages that exceed 35 volts.

7-3-1-6. Power Supply

Relay RLA selects which secondary tap of transformer T1 is applied to the bridge rectifier composed of diodes D103-D106. Capacitor C101 smoothes the rectified AC voltage. Relay RLA is controlled by the comparator circuit to provide a higher voltage to the output stage to reduce settling time when an inductive load is being charged.

7-3-1-7. Charging Inductor Mode

The gate voltage of TR103 is compared to a reference voltage defined by D107-D109. When the gate voltage exceeds the reference voltage, TR105 conducts which energizes relay RLA and opto-coupler IC102-B. Transistors TR104 and TR105 form a Schmidt trigger circuit to reduce relay chattering. Buffer IC101-B isolates the gate drive circuit from the comparator to reduce rail injected noise.

7-3-2. Voltmeter/Control Logic

The operation of the voltmeter and control logic is described in the following paragraphs. Component references in this section can be found on Schematic 4300-072 Sheet 2.

7-3-2-1. A-D Converter/Clock

Most of the A-D converter circuitry is contained in IC's 202 and 203 along with their associated components. IC202 contains the digital section of a 4½ digit dual slope A-D converter; the analog section is contained in IC203.

The operating cycle of the dual slope integrating A-D converter is divided into three phases, whose duration is set by an external clock. The clock is provided by IC201, a self contained 100KHz CMOS crystal controlled oscillator.

During the first, or Auto Zero phase, the A-D input is internally shorted to analog ground and C203 is charged to the integrator's output offset voltage.

During the next two phases, the capacitor voltage subtracts from the analog input to cancel the offset.

During the second, or input integrate phase, the input voltage is connected to the integrator via the buffer composed of IC204 and associated components. IC203 integrates the input for a precise time (10,000 counts of the clock) by charging

C204 linearly towards the input voltage. The buffer gain is controlled by analog switch IC207 and relay RLK.

The gain of the buffer along with the reference voltage determines the A-D converter's full scale range. The A-D converter's full scale voltages are tabulated in Table 7-1. The gain is determined by the position of the voltage range selector on the 4300B front panel.

Table 7-1. A-D Converter Buffer Gains

Voltage Range	Reference Voltage (pin 7 of IC202)	(IC204) Buffer Gain	Full Scale Input Voltage
20mV	10mV	100	19.999mV
200mV	100mV	10	199.99mV
2V	1V	1	1.9999V

The waveform on C204 is a very linear ramp whose slope is proportional to the input voltage. Thus, the charge on C204 at the end of the integrate phase is also proportional to the input voltage. During the third or reference integrate phase, a fixed reference voltage of polarity opposite the input voltage is applied to the integrator. IC203 begins discharging C203 toward the reference voltage.

Because this voltage is fixed, the discharge slope is constant. Therefore, the time required to discharge C203 back to zero is proportional to the input voltage. This time is measured by an internal counter in IC202. These counts are latched in a multiplexer, also internal to IC202, at the end of the count period. The result is a multiplexed BCD output proportional to the input voltage. The full scale voltage input to the A-D converter is dependent on the buffer gain and also on the reference voltage.

7-3-2-2. Reference Generator

The reference generator provides one of three voltages to the A-D converter to determine its sensitivity. IC205 is an oven stabilized zener diode providing a 6.95 volt nominal output to the voltage divider composed of R212, R213, RV202 and R214. R214 is replaced with the temperature compensator when using Options "CU" and "AL" in the ATC mode.

The output of the voltage divider is amplified by IC206 and associated components. Variable resistor RV203 allows adjustment of the amplifier gain to establish a 1.0000 volt reference. The 1.0000 volt reference is applied to the voltage divider composed of R218-R220, RV204 and RV205. The voltage divider provides 100.00mV and 10.000mV outputs.

Analog switch IC207 selects which reference voltage is applied to the A-D converter per Table 7-1. If the ATC compensator connector is open-circuited and ATC mode is selected the output of IC206 goes to the positive rail. If this happens, the FAULT LED is triggered through D204. Diode D204 provides level shifting to produce a TTL compatible signal to the control logic.

7-3-3. Display Board

The following paragraphs detail the operation of the 4300B display board. All component references can be found on Schematic 4300-073 Sheets 1 and 2.

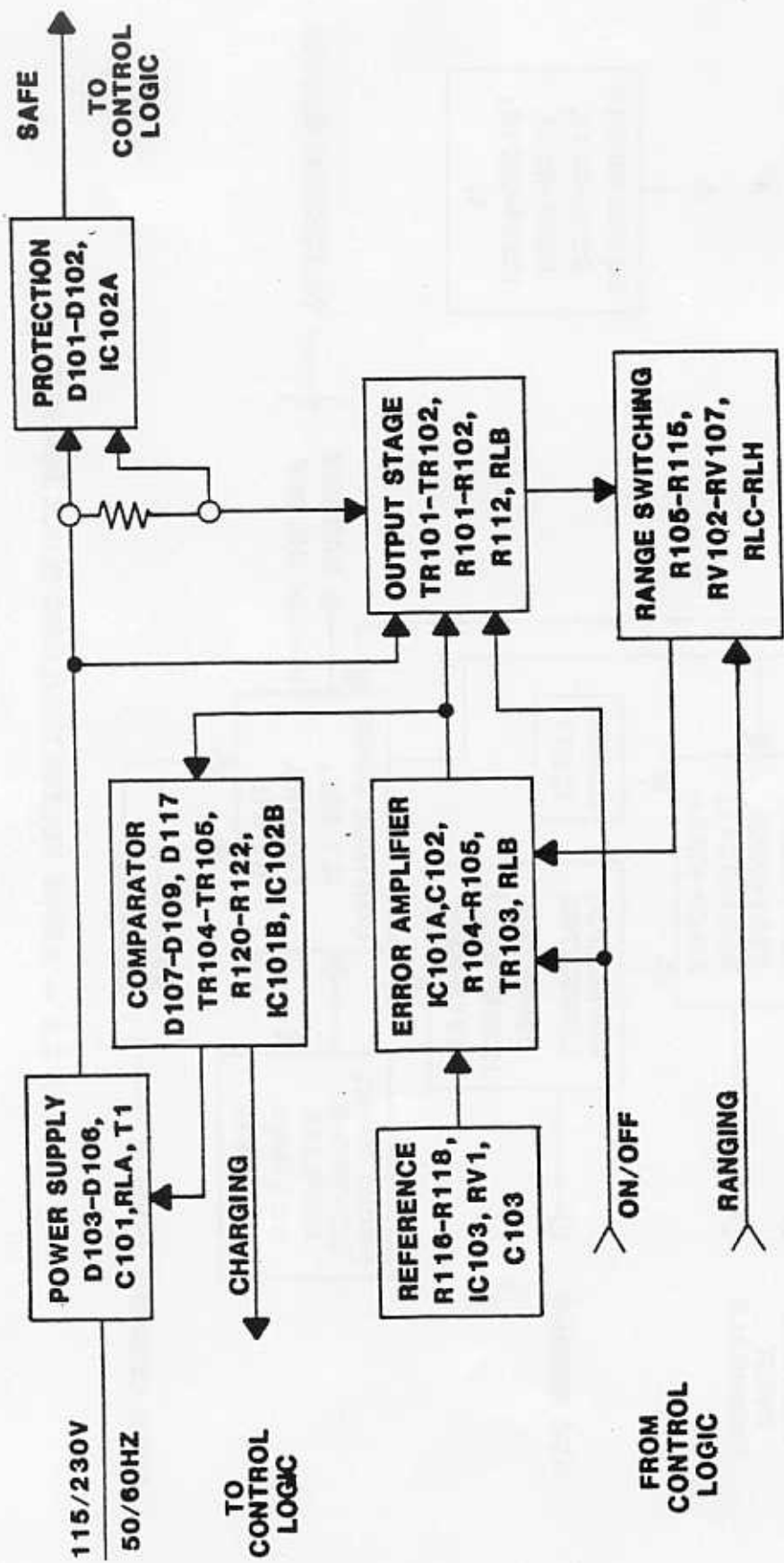

FIGURE 7.1 - 4300B CURRENT SOURCE BLOCK DIAGRAM



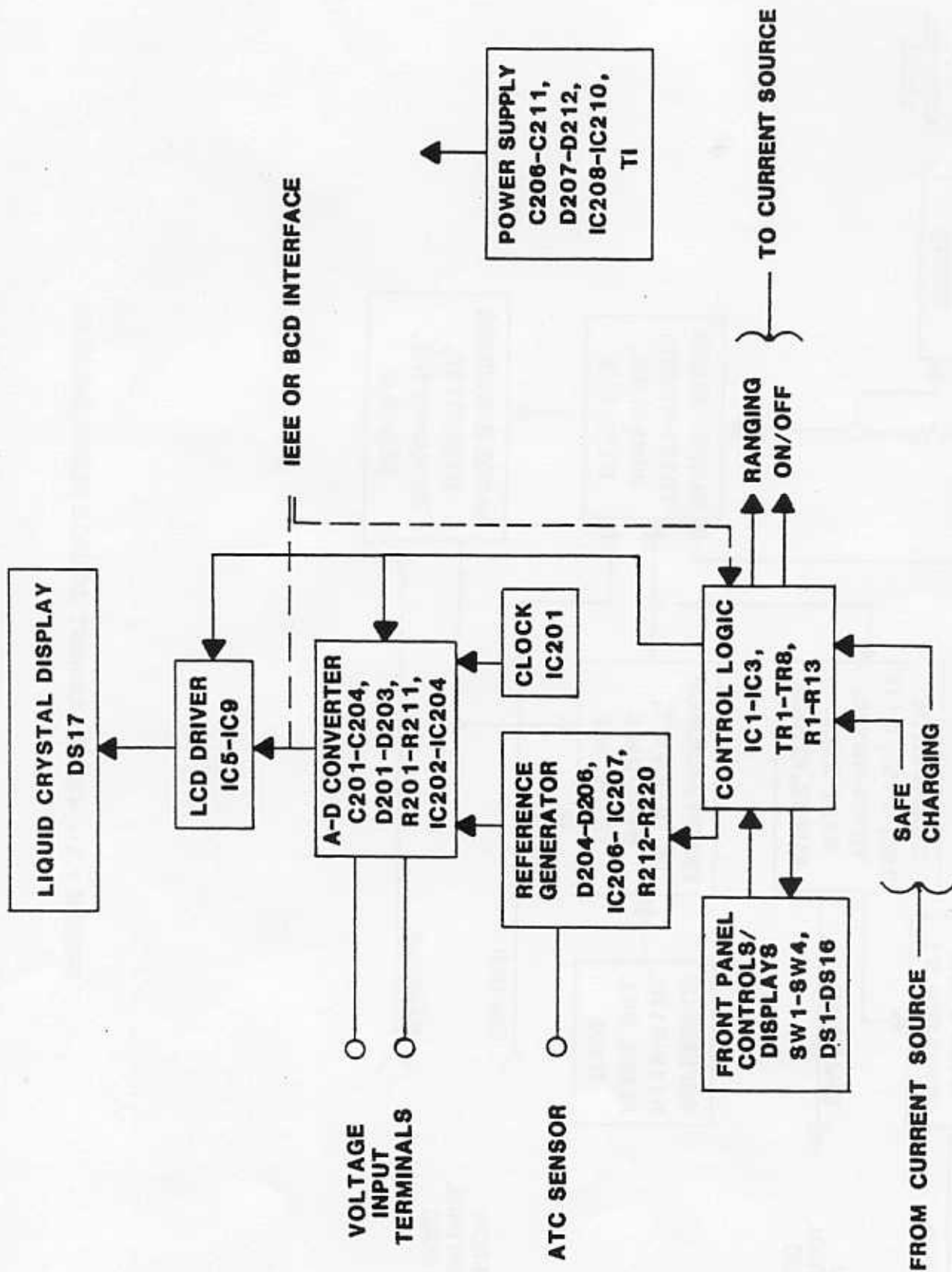

FIGURE 7.2 — 4300B VOLTMETER/LOGIC BLOCK DIAGRAM



7-3-3-1. *Liquid Crystal Display*

Most of the LCD driver circuitry is contained in IC7. IC7 decodes the multiplexed BCD and provides proper signal levels necessary to drive the LCD. The multiplexed BCD from the A-D converter is buffered before going to IC7 via IC's 8 and 9.

The four least significant digit lines are qualified by the Strobe signal from the A-D converter. The lines are overranged by the Overrange signal from the A-D converter. When an overrange occurs, the digit lines go to a high state. The display driver blanks the display for this input code. IC6 provides level shifting to drive the polarity sign and the "1" digit. The decimal points are driven via exclusive-or gate IC5.

7-3-3-2. *Front Panel Controls*

The front panel controls utilize negative-true TTL logic levels, with "0" being the asserted state. The front panel controls are enabled via transistor TR1. The option "TL-488" PCB pulls the REM line low to disable the front panel controls when operating remotely via the bus (see Section 5).

LED DS2 is illuminated when the REM line is low, indicating remote operation. The front panel controls are diode ranged with the outputs of the "TL-488" PCB to allow remote operation.

The voltage and current ranges are determined by IC2 and IC3. IC3 is a BCD-to-decimal converter which decodes the current range switch and provides a one-of-six active-low output that drives LED's DS8-DS13 and the current source range relays.

The current and voltage range switch information also goes to the PROM, IC2. The PROM provides three outputs to drive the voltage range LED's DS14-DS16 and the A-D converter reference selector IC207 (See Section 7-3-2-2). The PROM decodes the voltage and current range information to enable the four decimal point lines to the LCD driver circuitry. Another output from the PROM triggers the cable disconnect status logic and is composed of TR3, TR6-TR8 and their associated components. This logic determines that it is unsafe to disconnect the cables when:(a)the Test Current is On and 100mA or greater current is selected or (b)the back EMF from a load is greater than five volts (See Section 7-3-1-5).

The Charging Inductor LED is driven by the CHG signal via transistor TR4. The Test Current On LED is driven by TR2 and its associated components. TR6 drives the current source Test Current Off relay, RLB.

The ATC ON LED and ATC relay (RLJ) in the reference generator are driven by TR5 (See Section 7-3-2-2).

7-3-3-3. *Power Supplies*

Power for the voltmeter and control logic circuits is provided by two windings of transformer T1. The AC voltages are rectified by diodes D207-D212. See Schematic 4300-072 Sheet 2.

These raw DC voltage levels are regulated by IC's 208 to 211 to produce +5V, +15V, -15V, and +12V respectively. IC211 is mounted on the rear panel and provides the +12VDC necessary to power the cooling fan.

7-4. Troubleshooting

Apparent malfunctions are often the result of misinterpretation of specifications or due to an incomplete understanding of the instrument. A thorough review of the operating instructions for this instrument is recommended prior to any component replacement, etc. Check to be sure that cables and other test equipment are in good working order before attempting to troubleshoot the 4300B.

If the Model 4300B exhibits problems that cannot be eliminated by reviewing Sections 2, 4, 5, 7, or 9, the following guidelines have been established to help solve the problem.

7-4-1. Localizing the Problem

The key to successful troubleshooting is to localize the problem as much as possible before trying to pin the problem down to a specific component. Certain questions should be asked such as "Does the problem occur on all ranges or on a specific range only?". The power supplies are also one of the first things that should be checked.

As it is not possible to anticipate all failure modes of the 4300B, servicing personnel should become familiar with Section 7 to gain a complete understanding of the internal workings of this instrument.

7-4-2. Component Replacement

If the problem has been identified as a faulty component, the accuracy of the 4300B can be maintained only if the following precautions are taken:

▲ Use only the specified component or its exact equivalent. Spare parts can be ordered from your nearest Valhalla Scientific Service Center or from the factory directly by referring to the Valhalla Stock Number listed in the Parts Lists section at the back of this manual.

▲ Use only 63/37 grade rosin core electronic grade solder with a 50W or lower maximum power soldering iron.

▲ When soldering, heat the terminal of the component, not the solder. Apply solder smoothly and evenly. Do not move the component until the solder has cooled. Bad solder joints can cause additional problems!

▲ Static sensitive parts require special handling procedures. Always treat an unknown part as if it were static sensitive.

SECTION VIII CALIBRATION PROCEDURE

8-1. General

This section provides general maintenance information and a procedure for calibrating the 4300B. The 4300B Digital Micro-ohmmeter should be calibrated on a routine basis (annually is recommended) to ensure continued accuracy. The 4300B should also be regularly dusted using dry, compressed air to remove any debris.

Before performing the calibration procedure that follows, the 4300B should be warmed up for at least 30 minutes with the top cover in place. The top cover should be replaced after each adjustment has been made. Allow time for the unit to restabilize after making each adjustment.

8-2. Required Test Equipment

The following test equipment is required to calibrate the 4300B Digital Micro-Ohmmeter:

- 1) DC Voltage Standard with available outputs of 1.0000V, .1000V, .010000V $\pm 0.005\%$ (Valhalla 2701C or equivalent)
- 2) Precision Standard Resistors with known values to within $\pm 0.005\%$

0.1000 Ω
1.0000 Ω
10.000 Ω
100.00 Ω^*
1000.0 Ω^*
10000 Ω^*

* May be replaced by Valhalla Model 2724A

- 3) Heavy duty cables capable of carrying 10 amperes of current

8-3. Voltmeter Calibration

The following procedure describes calibration of the voltmeter section of the 4300B. In all steps the Test Current should be turned Off, and the .1mA Current Range selected.

8-3-1. Zero Adjustment

Select the 20mV range and apply +0.00001VDC. Adjust RV201 for a reading of 00.10 (± 5 digits drift maximum)

8-3-2. ATC Balance Adjustment

This adjustment should be performed only if components have been replaced and need not be performed on a routine basis.

Select the 2V range. Apply 1.0000VDC to the input terminals and connect a precision 1.00K .05% resistor to the ATC connector. Alternately select and deselect the ATC mode. Adjust RV202 for minimum shift in readings between normal and ATC modes.

8-3-3. 2 Volt Range Adjustment

Select the 2V range and apply +1.0000 volts to the voltage input terminals. Adjust RV203 for a reading of 10000

8-3-4. 200mV Range Adjustment

Select the 200mV range and apply +.10000 volts to the voltage input terminals. Adjust RV204 for a reading of 1000.0

8-3-5. 20mV Range Adjustment

Select the 20mV range and apply +10.000mV to the voltage input terminals. Adjust RV205 for a reading of 100.00

8-4. Current Source Calibration

The following procedure should be performed when calibrating the current source section of the 4300B. In all steps the current source is calibrated to the internal voltmeter therefore the voltmeter calibration of Section 8-3 should be performed before proceeding. Alternately, an external voltmeter of greater than $\pm 0.005\%$ accuracy may be used.

8-4-1. Reference Adjustment

This adjustment should only be performed if components in the reference section have been replaced and need not be performed on a routine basis. A DC voltmeter with a minimum of $\pm 0.03\%$ accuracy is needed to make the adjustment.

Connect the voltmeter low lead to 0V (front of R118) and the voltmeter high lead to IC101 pin 5. Adjust RV101 for 1.0000 volts. Remove the voltmeter leads.

8-4-2. 10 Amp Adjustment

Connect the .1 ohm standard resistor to the 4300B using four-wire connections. Select the 2V and 10A ranges on the 4300B. Adjust RV102 for a reading of 100.00m Ω . Allow extra time for settling in this range. Keep the cover on as much as possible to ensure proper cooling of components.

8-4-3. 1 Amp Adjustment

Connect the 1 ohm standard resistor to the 4300B using four-wire connections. Select the 2V and 1A ranges. Adjust RV103 for a reading of 1000.0m Ω .

8-4-4. 0.1 Amp Adjustment

Connect the 10 ohm standard resistor to the 4300B using four-wire connections. Select the 2V and .1A ranges. Adjust RV104 for a reading of 10000mΩ.

8-4-5. 10mA Adjustment

Connect the 100 ohm standard resistor to the 4300B using four-wire connections. Select the 2V and 10mA ranges. Adjust RV105 for a reading of 100.00Ω.

8-4-6. 1mA Adjustment

Connect the 1000 ohm standard resistor to the 4300B using four-wire connections. Select the 2V and 1mA ranges. Adjust RV106 for a reading of 1000.0Ω.

8-4-7. 0.1mA Adjustment

Connect the 10000 ohm standard resistor to the 4300B using four-wire connections. Select the 2V and .1mA ranges. Adjust RV107 for a reading of 10000Ω.

SECTION IX SPECIAL PROCEDURES

9-1. General

This section contains a number of useful tips that should be noted when working with inductive loads. Inductive loads include devices such as transformers, coils, ballasts, wire-wound resistors, magnets and motors. These types of devices require special consideration as described below.

9-2. Connections and Settling Time

When connecting the cables to the inductive load, care should be taken not to draw an arc. The Test Current should be turned Off and the cables positively clamped onto the load before applying current.

When measuring highly inductive loads the settling time of the ohmmeter is determined by the compliance voltage of the current source. Typically, the compliance voltage of a 4300B in the Charging Inductor mode is in excess of 20 volts. Thus, with an inductor of 1000 Henries (an extremely large transformer) the unit will take approximately 10 minutes to settle. During settling, the unit will display overload and should be ignored until the Charging Inductor indicator is extinguished.

The actual equation for determining settling time is as follows:

$$T = (L \times I)/V$$

Where:

- T = settling time in seconds
- L = inductance in Henries
- I = current range (in amps)
- V = compliance voltage of 4300B (20V)

Note that the higher the test current, the longer the settling time.

9-3. Noisy Readings

When measuring very low resistances of highly inductive loads, care should be taken to reduce 60Hz pickup at the input to the 4300B. The noise pickup is caused by the very high impedance of the load at 60Hz given by the formula:

$$Z = 377 \times L$$

Where:

- Z = Impedance in ohms
- L = Inductance in Henries

Thus, with a 1000 Henry transformer the impedance at 60Hz would be 377Kohm, across which many millivolts of noise may be induced by movement or by interference from other devices.

This effect may be reduced by using fully shielded cables such as Valhalla Option "K". It may also be helpful (and will cause the settling time to be reduced) if the unused windings of the transformer can be short-circuited during the measurement. This will significantly reduce the inductance of the winding under test, and will also prevent the unused windings from producing dangerous voltages during charging and discharging of the transformer.

When using the 20mV voltage range, the measurement may be subject to the effects of thermal EMF's. This effect is seen as noise on the display. The best way to reduce this effect is to use a low-thermal lead set such as Valhalla Option SL-48.

9-4. *Disconnecting the Cables*

When disconnecting the test leads from the load or from the 4300B, extreme care must be taken to ensure that the inductor has been discharged to prevent an extremely high energy, high voltage "kick-back" which can be LETHAL to the user and can certainly damage the 4300B. There are two methods of discharging the energy in the inductor listed below.

a) Using the "Flyback Diode" in the 4300B.

As discussed in Section 7-3-1-5, the 4300B has an internal diode which can sink the excess current being discharged from the inductor. Therefore turning off the test current and/or reducing the 4300B's current range from the original test current to a low value (less than 10mA) will automatically discharge the inductor into the Flyback diode. The cables should not be disconnected until the SAFE cable disconnect status LED is illuminated.

The time required to discharge the inductor into the Flyback diode is given by the formula:

$$T = (L \times I)/V$$

T = Discharge time in seconds

L = Inductance in Henries

I = Current range (in Amps)

V = Flyback Diode voltage drop
(typically 6 volts)

For example, a 1000 Henry inductor will take approximately 30 minutes to discharge. During discharge the 4300B display will read overload until the inductor has completely discharged. The reading will then return close to zero.

b) Using a Shorting Switch

When using a shorting switch instead of the 4300B flyback diode, the current stored in the inductor discharges through the cables and switch. This current discharges with a time constant calculated from the formula below which is dependent on the test current that was used to charge the inductor:

Test Current Range Used:	Discharge Time (in Seconds):
10 Amps	$7 \times L \div R$
1 Amp	$5 \times L \div R$
.1 Amp	$2 \times L \div R$
< .1 Amp	Not required

Where:

L = Inductance in Henries

R = Total resistance of cables, switch and inductor (in ohms)

In a typical application R might be approximately 1 milliohm (.001Ω) and L might be 1000 Henries. If the 10 amp range of the 4300B was used to measure the inductor, 7,000,000 seconds are required (11½ weeks) to discharge it. The 4300B may be disconnected at any time provided the short circuit is maintained across the winding.

SECTION X MANUAL CHANGES

Immediately following this page may be found any notices regarding Operation Manual changes, or operating considerations for special variations of the ohmmeter. Please refer to any applicable material before attempting to operate your Micro-Ohmmeter.

Addendum 10-1

4350ATE Specifications

ADDENDUM 10-1: 4350ATE Specifications

The Valhalla Model 4350ATE High-Speed Digital Micro-ohmmeter is a variation of the Model 4300B ohmmeter. The 4350ATE has been specially designed for use on assembly lines to make high speed resistance measurements. The 4350ATE is designed to be controlled by a computer, however it may also be used via the front panel display by heeding several restrictions which are listed below.

The operating principles of the 4350ATE are very similar to the 4300B, and most points discussed in this manual apply to both instruments. The 4350ATE may be used manually (see Section 4) in all ranges with the following exceptions: 20mV/.1mA, 20mV/1mA, and 200mV/.1mA. The use of these ranges is restricted to remote operation due to noise characteristics. Remote operation is described in Section 5. (Also see Programmer's Notes below.)

Programmer's Notes:

- 1) The conversion rate of the 4350ATE is increased to 80ms.
- 2) Due to the high speed of the 4350ATE, resistance readings must be averaged when using the following combinations of voltage and current ranges:

Range	Minimum
20mV/.1mA	5 conversions
20mV/1mA	3 conversions
20mV/10mA	2 conversions
200mV/.1mA	5 conversions
200mV/1mA	3 conversions
2V/.1mA	3 conversions
2V/1mA	2 conversions

- 3) All other commands, functions and precautions remain the same.