

4440

Digital Multimeter-Counter

Instruction and Maintenance Manual

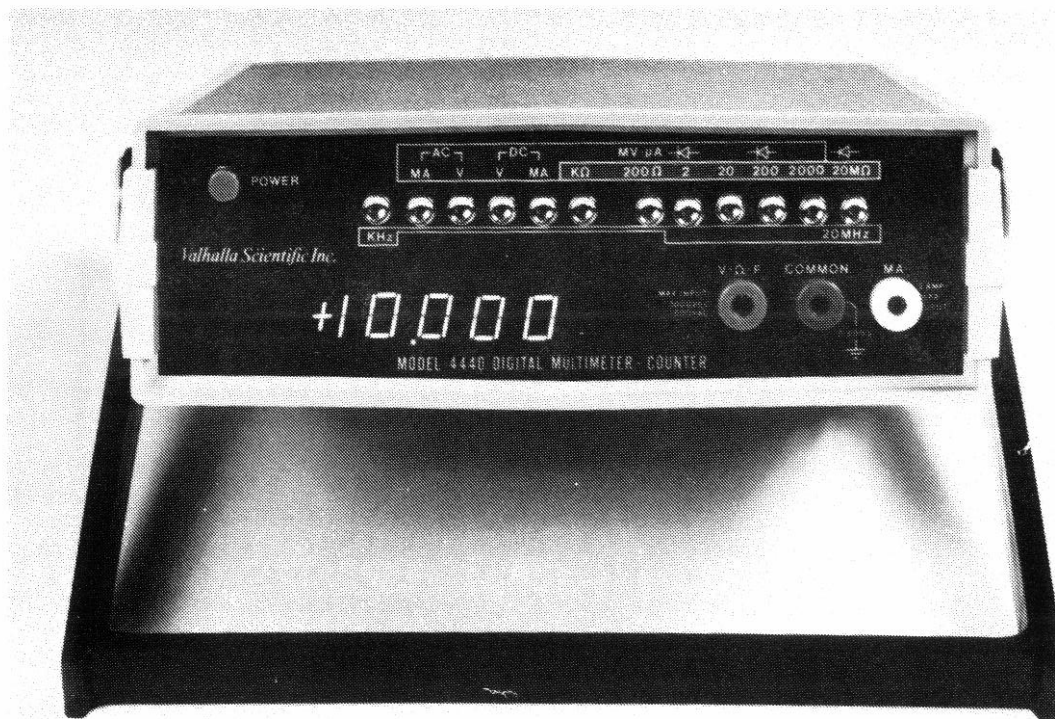

VALHALLA
SCIENTIFIC

9955 Mesa Rim Rd
San Diego CA 92121
Phone # (619) 457-5576
Telex # 181750

Rev. 9-85

CERTIFICATION

Valhalla Scientific, Inc. certifies that this instrument was thoroughly tested and inspected and found to meet its published specifications when it was shipped from the factory. Valhalla Scientific, Inc. further certifies that its calibration measurements are traceable to the National Bureau of Standards to the extent allowed by NBS's calibration facility.

WARRANTY

The warranty period for this instrument is stated on your invoice and packing list. Please refer to these to determine appropriate warranty dates. We will repair or replace the instrument during the warranty period provided it is returned to Valhalla Scientific, Inc. freight prepaid. No other warranty is expressed or implied. We are not liable for consequential damages. Permission and a return authorization number must be obtained directly from the factory for warranty repair returns. No liability will be accepted if returned without such permission.

MODEL 4440
SPECIFICATIONS

DC VOLTS

Range: 200 mv, 2, 20, 200, 1000 volts
Accuracy: $\pm 0.05\%$ of Reading, $\pm 0.025\%$ F.S.
Resolution: 0.005% F.S.; 10 μ volts on lowest range
Input Impedance: 1000 Megohms on 200 mv and 2V range
10 Megohms on all other ranges
NMR: 50 db
CMR: Near infinite (Battery operated)
Max Input: 1000V

AC VOLTAGE (AVERAGING)

Range: 200 mv, 2, 20, 200, 500 VRMS
Accuracy: 0.25% of Reading, $\pm 0.25\%$ of F.S.
Frequency: 45 Hz to 10 KHz
Resolution: 0.005% F.S., 10 μ volts on lowest range
Input Impedance: 1000 Megohms on 200 mv and 2V range
10 Megohms on all other ranges
Shunt Capacity: 50 pF
Max Input: 500 volts

AC VOLTAGE (RMS)

Ranges: 200 mv, 2V, 20V, 200V, 500V
Accuracy: (From 5% of Range to Full Scale) $\pm 0.5\%$ of reading
 $\pm 0.2\%$ of range (40 Hz to 10KHz) $\pm 1\%$ of reading
 $\pm 0.2\%$ of range (10 KHz to 20 KHz)
Input Impedance: 1000 Megohms on 200 mv and 2V range
10 Megohms on all other ranges
Crest Factor: 3:1, Peak voltage not to exceed 150% of range to
maintain full accuracy
Maximum Safe Input: 130 VRMS on 200 mv and 2V range
750V Peak on all other range not to exceed
10⁷ volt-hertz

RESISTANCE

Range: 200 Ohms, 2 KOhms, 20 KOhms, 200K Ohms,
2000K Ohms, 20 MOhms
Accuracy: 0.1% of Reading, $\pm 0.05\%$ of F.S. to 2 MOhms;
0.5% of Reading, $\pm 0.1\%$ of F.S. above 2 MOhms;
Resolution: 0.005% of F.S.; 10 milliohms on lowest range
Max Input Volts: 250 VDC or Peak AC

FREQUENCY COUNTING

Range: 2 KHz, 20 KHz, 200 KHz, 2000 KHz, 20 MHz
Accuracy: 0.01% of Reading, $\pm 0.005\%$ of F.S.
Resolution: 0.005% of F.S.; 0.1 Hz on lowest range
Gate Time: 1 KHz - 10 sec.; 10 KHz - 1 sec.; 100 KHz - 0.1 sec.;
1000 KHz - 0.1 sec.; 10 MHz - 0.1 sec.
Sensitivity: 100 mv to 1 MHz; 250 mv to 20 MHz

DC CURRENT

Range: 200 μ a, 2, 20, 200, 2000 ma
Accuracy: $\pm 0.3\%$ of Reading; $\pm 0.05\%$ of F.S.
Resolution: 0.005% of F.S.; 10 na on lowest scale
Current Shunt Voltage Drop: 200 mv F.S.
Max Input: 2 amperes on all ranges (Fuse protected)

AC CURRENT (AVERAGING)

Range: 200 μ a, 2, 20, 200, 2000 ma
Accuracy: 1% of Reading $\pm 0.1\%$ of F.S. to 10 KHz
Resolution: 0.005% of F.S.; 10 na on lowest range
Max Input: 2 amperes on all ranges (Fuse protected)

AC CURRENT (RMS)

Ranges: 200 μ a, 2, 20, 200, 2000 ma
Accuracy: (From 5% of range to Full Scale)
 $\pm 1\%$ of reading $\pm 0.2\%$ of range
Voltage Burden: 0.25V RMS maximum except 2000 ma range
0.7V RMS maximum on 2000 ma range
Crest Factor: 3:1, Peak current not to exceed 150% of range
to maintain full accuracy

GENERAL

Display: LED's 0000 to 19999
Accuracy: Specifications apply for 25°C $\pm 5^\circ$ C for 90 days
Temperature: 0 to 50°C
Max CMV: 1000 volts
Conversion Rate: Approximately 3 per second
Overload Indication: Flashing display
Autopolarity: Bi-polar displays (+) and (-)
Size: 8 1/2 W x 3 1/2 D x 2 1/2 H
Weight: Approximately 3 lbs.
Power Source: Disposable "D" cells supplied, rechargeable
battery optional

Specifications apply when tested in accordance with standard Valhalla Scientific test procedures.

TABLE OF CONTENTS

		Page No.
	SPECIFICATIONS	0-1 0-2
I	GENERAL INFORMATION	1-1
	1-1 Description	1-1
	1-3 Accessories	1-1
	1-5 AC Charger - Option A	1-1
	1-7 Rechargeable Batteries - Option B	1-1
	1-9 10 MHz Counter - Option F	1-1
	1-11 True RMS to DC - Option TRMS	1-1
	1-13 20 Amp Current Shunt - Option I	1-1
	1-15 Temperature Probe - Option TEMP	1-2
	1-17 Hi Voltage Probe - Option HV-2	1-2
	1-19 Internal Line Power - Option AC	1-2
	1-21 Input Cable Set - Option C	1-2
II	INSTALLATION	2-1
	2-1 Introduction	2-1
	2-3 Initial Inspection	2-1
	2-6 Power Requirements	2-1
	2-8 Installation	2-1
III	OPERATION INSTRUCTIONS	
	3-1 Introduction	3-1
	3-3 Front Panel Controls	3-1
	3-8 DC Voltage Measurements	3-1
	3-9 DC Current Measurements	3-1
	3-10 AC Voltage Measurements	3-2
	3-11 AC Current Measurements	3-2
	3-12 Resistance Measurements	3-2
	3-13 Frequency Measurements	3-2
IV	THEORY OF OPERATION	4-2
	4-1 Introduction	4-2
	4-3 Functional Description	4-2
	4-4 A/D Converter	4-2
	4-8 Reference Amplifiers	4-3
	4-10 AC to DC Converter	4-3
	4-12 Ohms to DC Converter	4-3
	4-14 Frequency Counter	4-4
	4-16 LED Display	4-4
V	MAINTENANCE	5-1
	5-1 Introduction	5-1
	5-3 Required Test Equipment	5-1
	5-5 Calibration Procedure	5-1
	5-7 DC Voltage Calibration	5-1
	5-12 Resistance Calibration	5-1
	5-14 AC Calibration	5-1
	5-18 Frequency Counter Calibration	5-2
	5-21 Troubleshooting	5-2
	5-26 Power Supplies	5-3
	5-28 LED Display	5-3
	5-30 Current Shunts	5-3

LIST OF ILLUSTRATIONS

		Page No.
Figure 4-1	Block Diagram.	4-1
Figure 5-1	Logic Table.	5-2
Figure 5-2	LED Pin Number Table	5-3
Figure 5-3	Alpha Character Table.	5-3
	TRMS AC Converter.	5-10
	TRMS AC Converter Schematic.	5-11
	PCB Assembly Diagram	5-12
	Schematic Diagram.	5-13
Parts List	Digital Multimeter, sheet 1.	5-5
Parts List	Digital Multimeter, sheet 2.	5-6
Parts List	Digital Multimeter, sheet 3.	5-7
Parts List	Digital Multimeter, sheet 4.	5-8
Parts List	RMS to DC Converter.	5-9

SECTION I
GENERAL INFORMATION

1-1 DESCRIPTION

1-2 The Valhalla Scientific Model 4440 Digital Multimeter-Counter is a complete wide-range multifunction measurement system in one package. This instrument measures: DC Voltage, AC Voltage, DC Current, AC Current, Resistance and Frequency. The Model 4440 features overload protected input circuits on all ranges and functions to insure damage free operation when operated within specified limits. It is powered with disposable "D" cells or with rechargeable nickel cadmium batteries.

1-3 ACCESSORIES

1-4 The Valhalla Scientific Model 4440 is shipped from the factory with a set of disposable "D" cells, or rechargeable batteries if the option is exercised, and an instruction manual.

1-5 AC CHARGER - OPTION A

1-6 The AC Charger option consists of a power transformer and rectifier system, in a sealed package, that plugs into the 115 VAC wall outlet and into the rear of the instrument. It will remove the load from the disposable batteries, thereby extending their useful life. The unit will charge nickel cadmium batteries and simultaneously power the instrument from the AC outlet.

1-7 RECHARGEABLE BATTERIES - OPTION B

1-8 The rechargeable battery option consists of four "D" size Nickel Cadmium cells that will power the instrument for 8 hours of continuous operation in the multimeter mode or for 6 hours in the frequency counter mode between recharging of the cells.

1-9 20 MHz COUNTER - OPTION F

1-10 The 20 MHz Counter option adds crystal controlled frequency counting capability up to 20 MHz. An automatic gain control on the input stage eliminates any adjustments over the dynamic range providing "hands off" operation.

1-11 TRUE RMS TO DC CONVERTER - OPTION TRMS

1-12 The Option TRMS allows the user to accurately measure non-sinusoidal wave forms.

1-13 EXTERNAL 20 AMPERE CURRENT SHUNT - OPTION I

1-14 The unit may be purchased with the external 20 Amp shunt option which extends the AC and DC current ranges to 20 Amperes full scale.

1-15 TEMPERATURE PROBE - OPTION TEMP

1-16 The option TEMP Temperature Probe will accurately measure surface temperatures from -50°C to 150°C.

1-17 HIGH VOLTAGE PROBE - OPTION HV-2

1-18 The High Voltage Probe, Option HV-2 extends the range of the basic instrument to 36,000V with 2% accuracy.

1-19 INTERNAL LINE POWER - OPTION AC

1-20 Option AC provides power directly from 115 VAC line, 200 VAC 50 Hz also available.

1-21 INPUT CABLE SET - OPTION C

1-22 The Model 4440 Option "C" Input Cable Set provides direct compatibility with the front panel input connectors through shielded conductor. The input leads are terminated in two alligator clips.

SECTION II INSTALLATION

2-1 INTRODUCTION

2-2 This section contains information for the inspection and installation of the Valhalla Scientific Model 4440 Digital Multimeter.

2-3 INITIAL INSPECTION

2-4 Before accepting the instrument from the shipper, inspect the shipping container for any signs of external damage. If damage is observed, please notify the carrier.

2-5 Unpack the instrument and retain the shipping container until the instrument has been inspected for possible damage in shipment.

2-6 POWER REQUIREMENTS

2-7 The Valhalla Scientific Model 4440 Digital Multimeter-Counter operates from a DC power supply consisting of four disposable "D" cells furnished with the instrument. Alternately, nickel-cadmium batteries may be used to extend the operational time between battery replacements. A charger is available as an option (see Section I) that will remove the load from the batteries when connected to the 115 volt AC wall outlet. It will also charge nickel cadmium batteries and simultaneously power the instrument from the AC outlet. Normal operating time between charges of the nickel cadmium batteries is 8 hours of continuous operation in the multimeter mode or 6 hours in the counter mode.

2-8 INSTALLATION

2-9 The Model 4440 is a low power device that generates little or no heat. Therefore, there are no special installation considerations other than to insure that its ambient environment is within the temperature range specified.

SECTION III OPERATING INSTRUCTIONS

3-1 INTRODUCTION

3-2 This section contains complete operating instructions for the Model 4440 Digital Multimeter-Counter. Included is a description of the front panel controls and a list of procedures required to operate the unit in each of its measurement modes.

3-3 FRONT PANEL

3-4 The POWER SWITCH is a single push-on push-off control located at the extreme right hand side of the panel. This control energizes and de-energizes the instrument.

3-5 The FUNCTION SWITCH is a six-station, interlocking pushbutton unit located in left center of the panel. This control selects any of the six functions, KHz, AC MA, AC V, DC V, DC MA, or $K\Omega$. In the event the KHz option is not exercised, then the KHz control is not present.

3-6 The RANGE SWITCH is a six-station, interlocking pushbutton unit located to the right of the panel center line. This control selects any of six multipliers to provide a wide range of inputs. The legends above the switch pushbuttons provide a quick reference when selecting a new range.

3-7 DC VOLTAGE MEASUREMENTS

The maximum safe input is 10,000% of range not to exceed 1000 VDC.

1. Press RANGE switch to 2000.
2. Press FUNCTION switch to DCV.
3. Connect the unknown input voltage across the front panel V- Ω -F and COMMON terminals.
4. Observe the reading and select the range that will yield the proper resolution.

3-8 DC CURRENT MEASUREMENTS

The maximum safe input is 500% of range not to exceed 2A.

1. Press RANGE switch to 2000.
2. Press FUNCTION switch to DCMA.
3. Connect the unknown input current across the front panel MA and COMM input terminals.
4. Observe the reading and select the range that will yield the proper resolution.

3-9 AC VOLTAGE MEASUREMENTS

The maximum safe input is 10,000% of range not to exceed 500V rms.

1. Press RANGE switch to 2000.
2. Press FUNCTION switch to ACV.
3. Connect the unknown input voltage across the front panel V- Ω -F and COMM input terminals.

4. Observe the reading and select the range that will yield the proper resolution.

3-10 AC CURRENT MEASUREMENTS

The maximum safe input is 500% of range not to exceed 2A.

1. Press RANGE switch to 2000.
2. Press FUNCTION switch to ACMA.
3. Connect the unknown input current across the front panel MA and COMM input terminals.
4. Observe the reading and select the range that will yield the proper resolution.

3-11 RESISTANCE MEASUREMENTS

The maximum safe input voltage is 200 VDC or peak AC.

1. Press FUNCTION switch to $K\Omega$.
2. Press RANGE switch to 20 $M\Omega$.
3. Connect the unknown input resistor across the front panel V- Ω -F and COMM input terminals.
4. Observe the reading and select the range that will yield the proper resolution.

NOTE

Use a shielded input cable when measuring high resistance values.

3-12 FREQUENCY MEASUREMENTS (with Option F installed)

The maximum safe input voltage is 250V rms.

1. Press FUNCTION switch to KHz.
2. Press RANGE switch to 20 MHz.
3. Connect the unknown input frequency across the front panel V- Ω -F and COMM input terminals.
4. Observe the reading and select the range that will yield the proper resolution. Out of range indications are characterized by a flashing display.

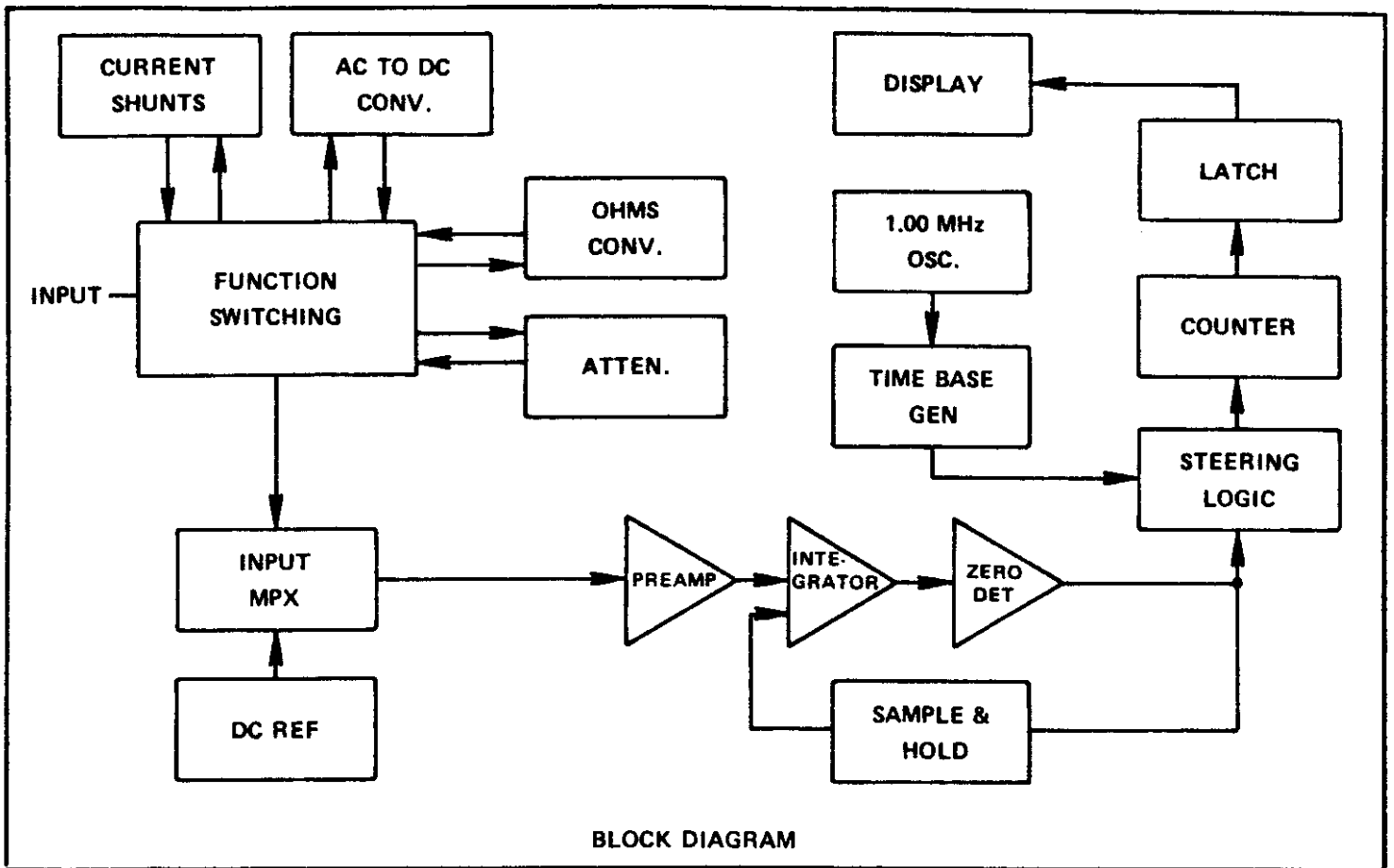

Figure 4-1

SECTION IV THEORY OF OPERATION

4-1 INTRODUCTION

4-2 The Valhalla Scientific Model 4440 Digital Multimeter-Counter is basically a precision analog to digital converter (A/D) that measures and displays DC voltages. The measurements of DC current, AC voltage, AC current and resistance are accomplished by first converting these inputs to DC voltages and then measuring them with the precision A/D converter. Frequency measurements are made by gating the unknown input frequency into the decade counter for a fixed period of time. The instrument is completely solid state and used CMOS integrated circuits almost exclusively to minimize the power required for operation. It is basically a DC powered unit using four "D" size cells of the disposable or rechargeable type.

4-3 FUNCTIONAL DESCRIPTION

4-4 A/D CONVERTER

4-5 The Model 4440 uses a three step integration process for converting analog input voltages into digital information. The first step is 200 milliseconds long and is the RESTORE mode. In this mode, the input to the amplifier, IC12, is grounded through one section of the quad-bilateral switch, IC2. The sample and hold switch, Q15, is ON, closing the feedback loop around the integrator, IC13, and the zero detector, IC14, to drive the output of the zero detector to zero and charge capacitor C21 to the level required to hold the output at zero in the absence of an input voltage. Any offsets in the preamplifier, integrator or zero detector are automatically cancelled out.

4-6 The second step in the process integrates the unknown input voltage and begins by disabling Q15 and connecting the input of the amplifier to the input of the instrument. Depending on the selected range, the amplifier will operate at a gain of 1 or gain of 10. A gain of 10 is selected by grounding R28 through one section of the quad-bilateral switch, IC3, in the ranges of 200mv, 20V and 2000V. In the other ranges the switch is open, R28 is not grounded and the gain is 1. The output of the amplifier is applied to the input of the integrator. The integrator output will rise to a level proportional to the input. During this period, the polarity of the output of the zero detector will be applied to the D input of one half of the dual D flip-flop, IC6. The integration will last for 100 ms. At the end of that time, the input to the flip-flop will be clocked through to its Q output storing the input polarity information.

4-7 At the beginning of the third step, the input of the preamplifier is disconnected from the unknown input and connected to a reference voltage of a polarity opposite to that of the unknown input voltage. The polarity stored at the Q output of IC6, terminal 1, determines which of the two reference voltages is applied to the input of the preamplifier. Whereas the slope of the integrator output and the level at the end of integration was a function of the input voltage in the preceding step, the slope during integration of the reference is constant. Therefore, an accurate measure of the time to integrate the reference to zero is an accurate measure of the input voltage. During this period, the crystal controlled clock is being

counted by IC7. When the zero detector output passes through zero, the counting of the clock is stopped and the count displayed on the LED readout. The zero detector also sets the monostable comprised of IC4 8-9-10 and IC4 11-12-13 which sets the unit back into the RESTORE mode for a period of 200 ms.

4-8 REFERENCE AMPLIFIERS

4-9 The two reference voltages, one positive and one negative, which will be applied to the input of the preamplifier during the third step of the measurement process must be precise and equal. These are developed in two of the amplifiers in IC15. The current for the reference zener is obtained from constant current source, Q9. The zener voltage is sensed by IC15 at terminal 3 and the feedback from the output to terminal 2 is selected to create an output of approximately -1.05 volts. This negative voltage is then applied to input terminal 6 through R66. The gain of the second amplifier of IC15 is set at -1 and the output is +1.05 volts. The feedback loop to the non-inverting input, terminal 5, of IC15 is from potentiometer R61 and permits adjustment of the balance between the two reference voltages. The two outputs are then connected to the quad-bilateral switch, IC2, which will switch the correct polarity to the voltage divider comprised of R21, R22, R23 and R24. The other quad-bilateral switch, IC3, will connect +1 volt, +0.1 volt, -1 volt or -0.1 volt to the input of the preamplifier depending on the polarity of the input signal and the gain of the amplifier as determined by the selected range.

4-10 AC TO DC CONVERTER

4-11 The Model 4440 is basically a DC voltmeter. It is necessary to rectify the AC input before applying it to the input of the A/D Converter. Rectification and amplification are accomplished in the circuits associated with Q7 and IC16. The AC input is applied to Q7, which operates as a source follower, through C9 and R38. Its output is coupled through C10 to the voltage divider R33-R34. The input to IC16 at terminal 3 is one-half of the input at Q7. The output of IC16 is coupled, through C16, to two diode rectifiers, CR7 and CR8. Through the network of R44-C17 and R45-C18, the output connects back through C15 to the inverting input of the amplifier. The amplifier will operate at a gain of 1 in the 2 volt full scale range. In the 200 millivolt range, the series combination of R36 and R37 is connected to ground, thereby changing the input level to terminal 2 of IC16 and the gain is increased to 10. The voltage at the cathode of CR8 will be the same for a 100 mv input as with a 1 volt input. The rectified AC is filtered through R46, R47 and C19. The DC component at the junction of R46 and R47 is proportional to the RMS value of the input AC voltage. This DC voltage is applied through the selector switch assembly to the input of the DC voltmeter section. The gain of the AC amplifier is 10 in ranges of 200 mv, 20 volts and 2000 volts. In ranges of 2 and 200 volts, the amplifier gain is 1.

4-12 OHMS TO DC CONVERTER

4-13 The OHMS to DC converter functions to generate a constant current through the unknown resistance connected across the input terminals. The voltage drop across the unknown is measured by the DC voltmeter and displayed as the unknown resistance.

The constant current source is comprised of two sections of IC15, IC17, Q8 and associated components. The +1.05 volt reference of IC15 terminal 7 is applied to terminal 13 through R58 and R59. The feedback to the summing junction is adjusted with R69 to produce -1V at the output terminal 14. This is applied to a floating differential amplifier input, terminal 9 of IC15. The positive feedback for this amplifier is from a voltage divider between the constant current source output, cathode of CR9, and ground. The output of the floating differential amplifier drives one input of IC17, which, in turn, drives the constant current source, Q8. The amount of current that will flow in the external resistance will be determined by the resistance between the constant current source output and the lower end of R75 which is connected to the input terminal. In the 200 Ω and 2K Ω ranges, the resistance is comprised of a single 1K ohm resistor, R90. The current through the unknown resistor is 1 ma. In the 20K Ω and 200K Ω ranges, a 99K ohm resistor, R84, is switched in series with R90 for a total of 100K ohms and the current is 10 microamps. In the 2M Ω and 20M Ω ranges, R83, a 9.9M ohm resistor, is added for a total of 10M ohms and the current is then 100 nanoamps.

4-14 FREQUENCY COUNTER

4-15 The frequency counter is a crystal controlled true gated time counter. The precision time bases are derived by a 1 MHz crystal driving a series of decade counters. The counters are contained in IC11 and are programmed by the range switch to count the crystal oscillator to 100,000 for the 0.1 second gate, to 1,000,000 for the 1 second gate and to 10,000,000 for the 10 second gate. During the count time, the gate is open and the unknown frequency is counted in IC7 and displayed on the LED readout at the end of the gate time. The unknown input frequency is applied to the gate of Q13 which is protected from overvoltage by the circuit of Q14. Q13 operated as a source follower and drives NAND gate IC18 to produce a square wave at terminal 6. In the four lower ranges, the output of IC18 is applied directly to the input of IC7. In the 2 MHz range, it is first divided by 10 in IC19 and then applied to the input of IC7. In the 20 MHz range, it is first divided by 10 in IC19 and then again by 10 in IC20 for a total division of 100. The input to IC7, then, will never be greater than 200 KHz.

4-16 LED DISPLAY

4-17 At the completion of the count, in any mode of operation, the count is stored in four registers in IC7. IC7 also has an internal oscillator which is set by C4 to approximately 10 KHz. There are four output terminals on IC7 (2,3,23 and 24) which are connected to decoder-driver IC10. These will be sequentially connected to the four internal registers of IC7 at a 10 KHz rate. Simultaneously, the four driver transistors, Q2 through Q5, will be turned on sequentially. When the data for the most significant digit is connected to the output of IC7, Q5 will be turned on and the decoded data will appear on DS2. When the next most significant digit data is connected to the output terminals of IC7, Q4 will turn on and the data will appear on DS3. The same process continues for DS4 and DS5 and then the process is repeated. Since the strobe rate is 10 KHz, the eye sees the display as being continuously illuminated.

5-26 POWER SUPPLIES

5-26 The +5 volt supply is obtained directly from the battery pack. The voltage will vary from 4.5 volts to 6.4 volts depending on battery type and condition. The -5 volt supply is obtained from a DC to DC converter and voltage regulator system. The DC to DC converter is comprised of T1, Q11 and Q12. The secondary output of T1 is rectified and filtered and then regulated to 5 volts by the emitter follower, Q10.

5-27 The -10V supply is obtained from the junction of CR19 and CR20.

5-28 LED DISPLAY

5-28 Figure 5-2 lists the connections to the individual LED seven segment display units.

LED PIN NUMBER TABLE		
	SEGMENT	PIN
	A	1
	B	13
	C	10
	D	8
	E	7
	F	2
	G	11
	D.P.	6

Figure 5-2

5-29 Figure 5-3 shows the alpha characters that indicate a malfunction in the unit.

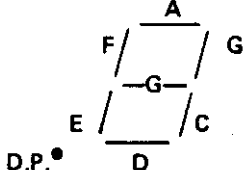

ALPHA CHARACTER TABLE					
10	11	12	13	14	15
					

Figure 5-3

5-30 CURRENT SHUNTS

5-31 In the event of a malfunction in the DC current function, the probable failure

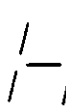
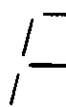
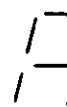
is the input protection fuse or the internal current shunt resistors. A simple continuity check will verify the integrity of the input fuse. The Valhalla Model 4440 may be used to trouble shoot its own current shunts. To check the current shunts, select the 2000 range and the $K\Omega$ function. Connect the V- Ω -F front panel terminal to the left side of R85 through R89 for signs of heat damage. Replace the defective resistor with a precision wire wound resistor of the same type and tolerance.

5-32 For troubleshooting the more complex feedback systems of the integrator, ohms converter and AC converter, refer to the theory of operation, Section IV.

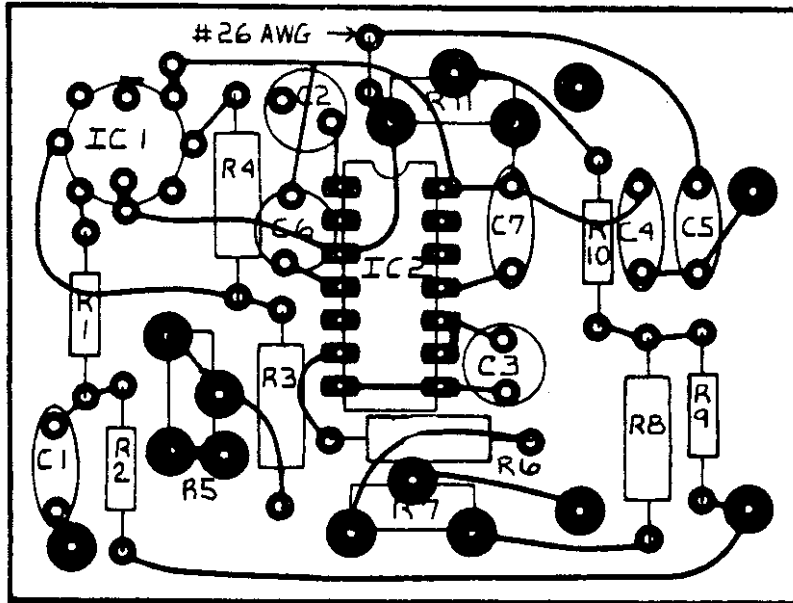

TRMS AC CONVERTER

CALIBRATION PROCEDURE

Select the ACV function and the 2 volt range. Apply 0.1000 VRMS at 1 KHz to the input terminals and adjust R11 for an indication of 0.1000 +5 digits.

Apply 1.0000 VRMS at KHz to the input terminals and adjust R7 for an indication of 1.0000 +5 digits.

Select the ACV function and the 200 MV range. Apply 100.00 MVRMS at 1 KHz to the input terminals and adjust R5 for an indication of 100.00 +5 digits.

Select the ACV function and the 20 volt range. Apply 10.000 VRMS at 10 KHz to the input terminals and adjust C37 for an indication of 10.000 +5 digits. (C37 is located behind the front panel input terminals).

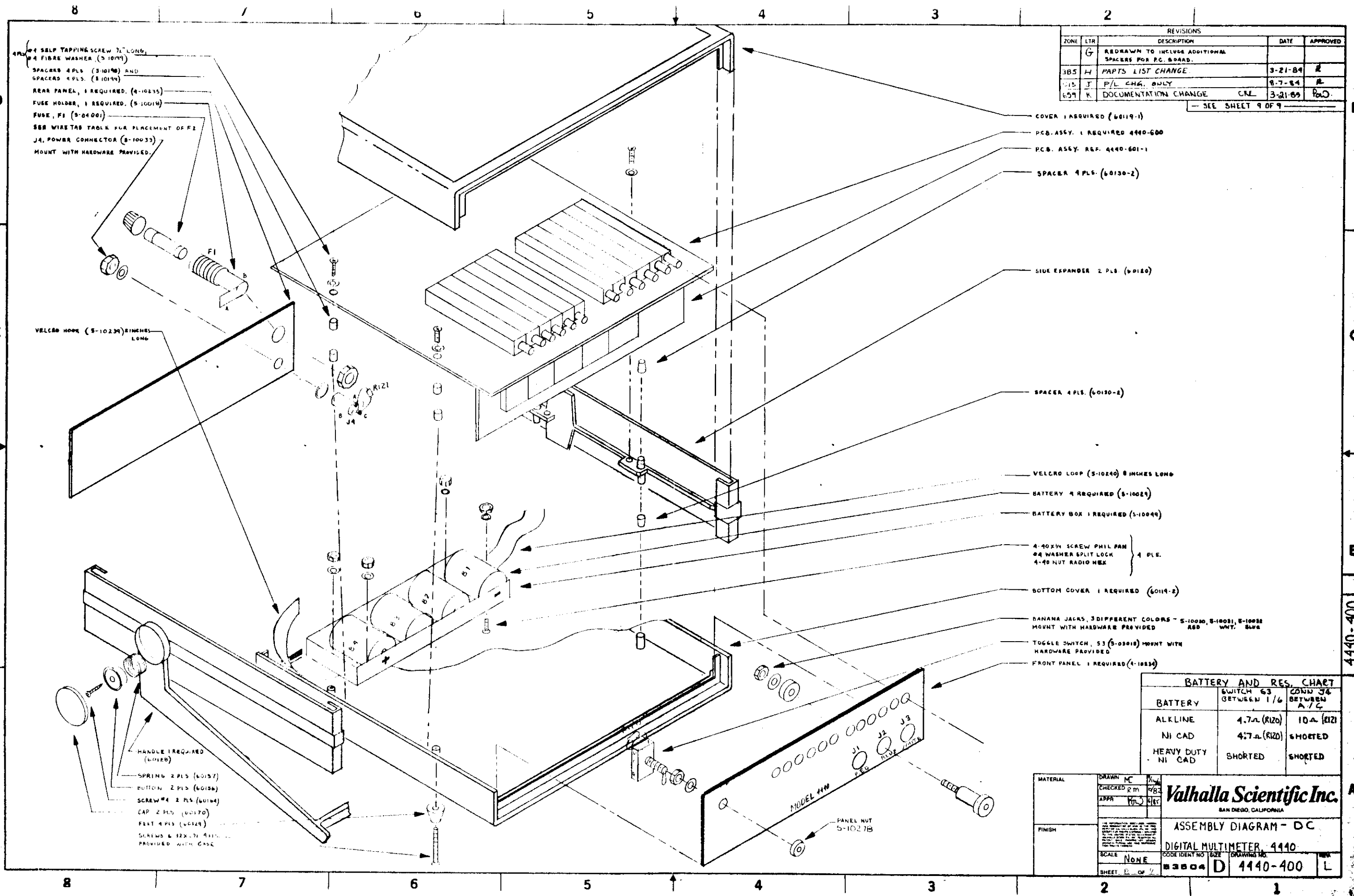

REVISIONS				
ZONE	LTR	DESCRIPTION	DATE	APPROVED
	G	REDRAWN TO INCLUDE ADDITIONAL SPACERS FOR P.C. BOARD.		
3B5	H	PAPTS LIST CHANGE.	3-21-84	R
115	J	P/L CHG. ONLY	8-7-84	R
657	K	DOCUMENTATION CHANGE	3-21-89	POD

- SEE SHEET 9 OF 9 -

- 4 #4 SELF TAPPING SCREW 3/8" LONG
- 4 #4 FIBRE WASHER (5-10194)
- SPACER 4 PLS (3-10198) AND SPACER 4 PLS (3-10194)
- REAR PANEL, 1 REQUIRED (4-10235)
- FUSE HOLDER, 1 REQUIRED (5-10019)
- FUSE, F1 (3-04001)
- SEE WIRE TAB TABLE FOR PLACEMENT OF F1
- J4, POWER CONNECTOR (8-10033)
- MOUNT WITH HARDWARE PROVIDED.

VELCRO HOOP (5-10234) 8 INCHES LONG

- HANDLE 1 REQUIRED (4-1128)
- SPRING 2 PLS (4-0157)
- BUTTON 2 PLS (4-0158)
- SCREW #4 2 PLS (4-0194)
- CAP 2 PLS (4-0170)
- FEET 4 PLS (4-0128)
- SCREWS & 12X72 4 PLS PROVIDED WITH CASE

- COVER 1 REQUIRED (4-0119-1)
- PCB ASSY. 1 REQUIRED 4440-600
- PCB ASSY. REF. 4440-601-1
- SPACER 4 PLS (4-0130-2)
- SIDE EXPANDER 2 PLS (4-0120)
- SPACER 4 PLS (4-0130-2)
- VELCRO LOOP (5-10240) 8 INCHES LONG
- BATTERY 4 REQUIRED (5-10021)
- BATTERY BOX 1 REQUIRED (5-10049)
- 4-40XVI SCREW PHIL PAN #4 WASHER SPLIT LOCK 4-40 NUT RADIO HEX } 4 PLS.
- BOTTOM COVER 1 REQUIRED (4-0119-2)
- BANANA JACKS, 3 DIFFERENT COLORS - 5-10020, 5-10021, 5-10022 MOUNT WITH HARDWARE PROVIDED RED WHT. BLUE
- TOGGLE SWITCH, 53 (5-03018) MOUNT WITH HARDWARE PROVIDED
- FRONT PANEL 1 REQUIRED (4-10834)

BATTERY	SWITCH 63 BETWEEN 1/6	CONN 34 BETWEEN A/C
ALKLINE	4.7Ω (R120)	10Ω (R121)
NI CAD	4.7Ω (R120)	SHORTED
HEAVY DUTY NI CAD	SHORTED	SHORTED

MATERIAL	DRAWN MC	DATE 7/83	Valhalla Scientific Inc. SAN DIEGO, CALIFORNIA
CHECKED RM	DATE 7/83	ASSEMBLY DIAGRAM - DC	
APPR PM	DATE 7/83	DIGITAL MULTIMETER, 4440	
FINISH	SCALE NONE	CODE IDENT NO. SIZE DRAWING NO.	3804 D 4440-400 L
	SHEET 8 OF 9		

4440-400

4 3 2 1

REVISIONS				
ZONE	LTR	DESCRIPTION	DATE	APPROVED
730	L	CHANGE FUSE ON PARTS LIST. R.D.N.	6-21-85	<i>[Signature]</i>

D
C
B
A

D
C
B
A

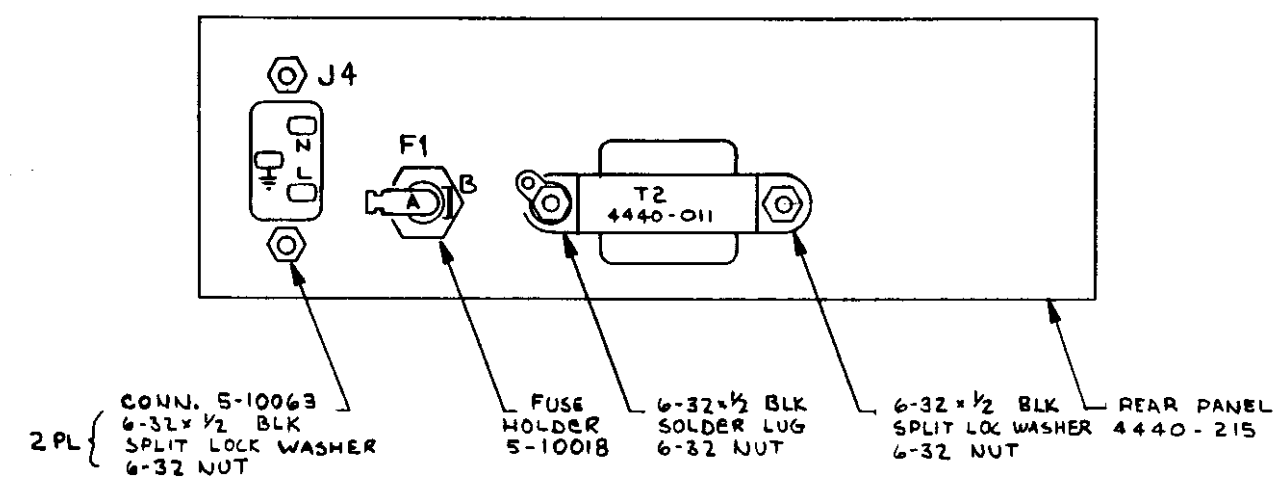

REAR PANEL ASSY FOR OPTION "AC" 4440/4314
STD "AC" 4020

- NOTES:
- FOR SCHEMATICS SEE:
 - MODEL 4440 4440-070
 - MODEL 4314 4314-070
 - MODEL 4020 4020-070
 - FOR PCB ASSY'S SEE:
 - MODEL 4440 4440-600
 - MODEL 4314 4314-600
 - MODEL 4020 4020-600
 - FOR PARTS LIST SEE:
 - MODEL 4440 DC 4440-400
 - MODEL 4314 DC 4314-400
 - MODEL 4020 AC 4020-400
 - FOR WIRING INFO SEE:
 - MODEL 4440 AC 4440-050
 - MODEL 4314 AC 4314-050
 - MODEL 4020 AC 4020-050
 - MODEL 4440 DC 4440-051
 - MODEL 4314 DC 4314-051

MATERIAL	DRAWN	RM	6/82	Valhalla Scientific Inc. SAN DIEGO, CALIFORNIA			
	CHECKED	RM	6/82				
	APPR.	RM	6/85				
FINISH	THE INFORMATION DISCLOSED HEREIN WAS ORIGINATED BY AND IS THE PROPERTY OF VALHALLA SCIENTIFIC INC. AND IS NOT TO BE REPRODUCED OR TRANSMITTED IN ANY FORM OR BY ANY MEANS, ELECTRONIC OR MECHANICAL, INCLUDING PHOTOCOPYING, RECORDING, OR BY ANY INFORMATION STORAGE AND RETRIEVAL SYSTEM, WITHOUT THE WRITTEN PERMISSION OF VALHALLA SCIENTIFIC INC. VALHALLA SCIENTIFIC INC. RESERVES ALL PATENT, TRADE, PROPRIETARY, DESIGN, MANUFACTURING AND OTHER RIGHTS THEREIN.			ASSEMBLY DIAGRAM - AC			
	SCALE	NONE	CODE IDENT NO.	SIZE	DRAWING NO.	REV	
	SHEET	9	OF	9	53504	C	4440-400

Optico 274-0151 4 3 2 1

REVISIONS				
ZONE	LTR	DESCRIPTION	DATE	APPROVED
	F	DS1 WAS 5082-7652-		

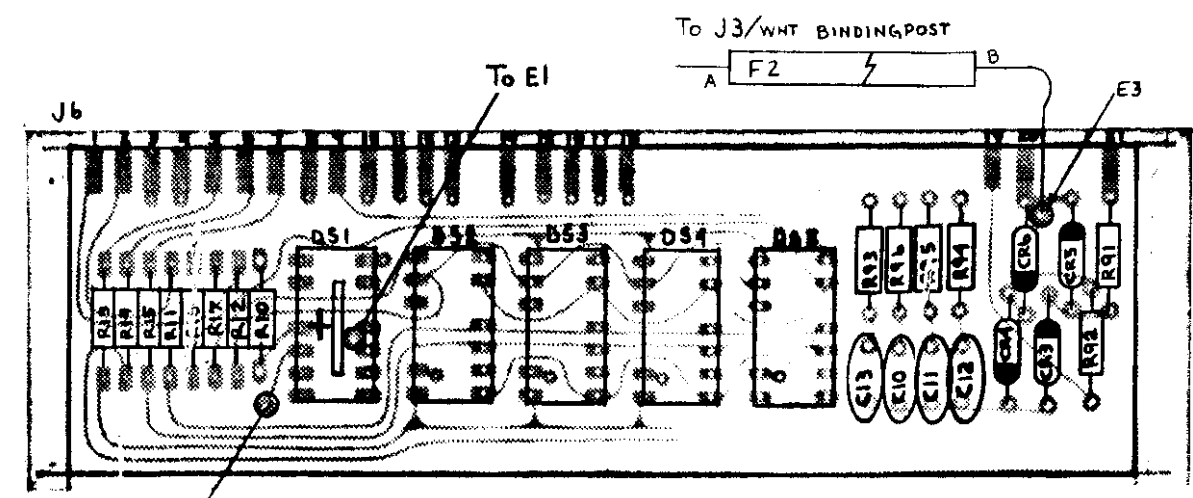

SHOWN IS P.C.B. ASSY. 4440-601-1
CLAD SHOWN IS FAR SIDE

3. FOR ASSY. SEE 4440-600
2. FOR WTT. SEE 4440-050
1. FOR SCHEMATIC SEE 4440-070

NOTES:

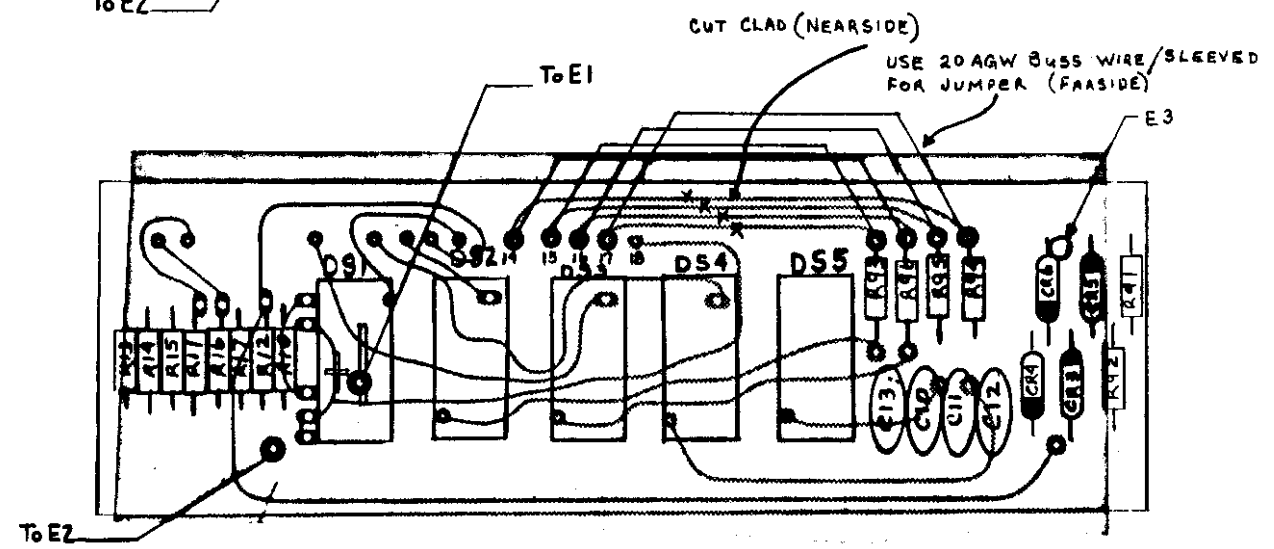

SHOWN IS P.C.B. ASSY. 4440-601-2
(CLAD SHOWN IS NEAR SIDE)

3. FOR ASSY. SEE 4314-600
2. FOR WTT. SEE 4314-050
1. FOR SCHEMATIC SEE 4314-070

NOTES:

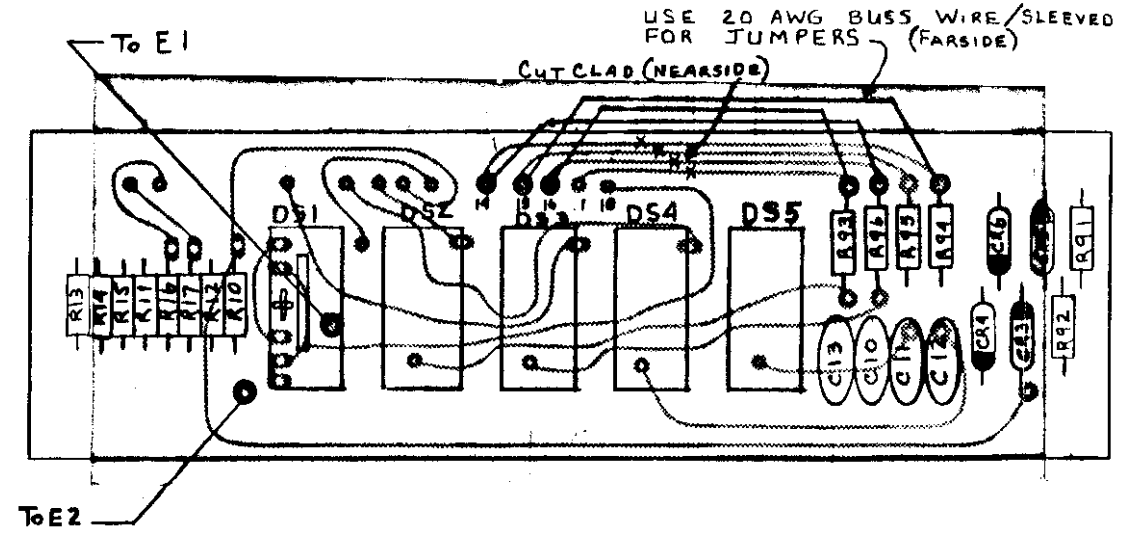

SHOWN IS P.C.B. ASSY. 4440-601-3
CLAD SHOWN IS NEAR SIDE

3. FOR ASSY. SEE 4020-600
2. FOR WTT. SEE 4020-050
1. FOR SCHEMATIC SEE 4020-070

NOTES:

MATERIAL	DRAWN M.C. 1/46	Valhalla Scientific Inc. SAN DIEGO, CALIFORNIA		
CHECKED R.M. 9/46	APPR.			
FINISH	<small>THE INFORMATION DISCLOSED HEREIN WAS OBTAINED BY AND IS THE PROPERTY OF VALHALLA SCIENTIFIC INC. AND IS NOT TO BE DISCLOSED OR REPRODUCED IN ANY MANNER WITHOUT THE WRITTEN PERMISSION OF VALHALLA SCIENTIFIC INC. VALHALLA SCIENTIFIC INC. RECEIVES ALL PATENT AND COPYRIGHT RIGHTS IN ALL MANUFACTURING USE AND REPRODUCTION RIGHTS THEREIN.</small>			ASSEMBLY DISPLAY P.C.B.
SCALE NONE	CODE IDENT NO. 53504	SIZE C	DRAWING NO. 4440-601	REV. F
SHEET 1 OF 1				

8 7 6 5 4 3 2

REVISIONS				
REV	DATE	DESCRIPTION	DATE	APPROVED
11	6/82	ADDED HOLES FOR BCD		
0127	11-8-83	DELETE JUMPER AND CROSS CONNECT AND REPAIR SECURITY		

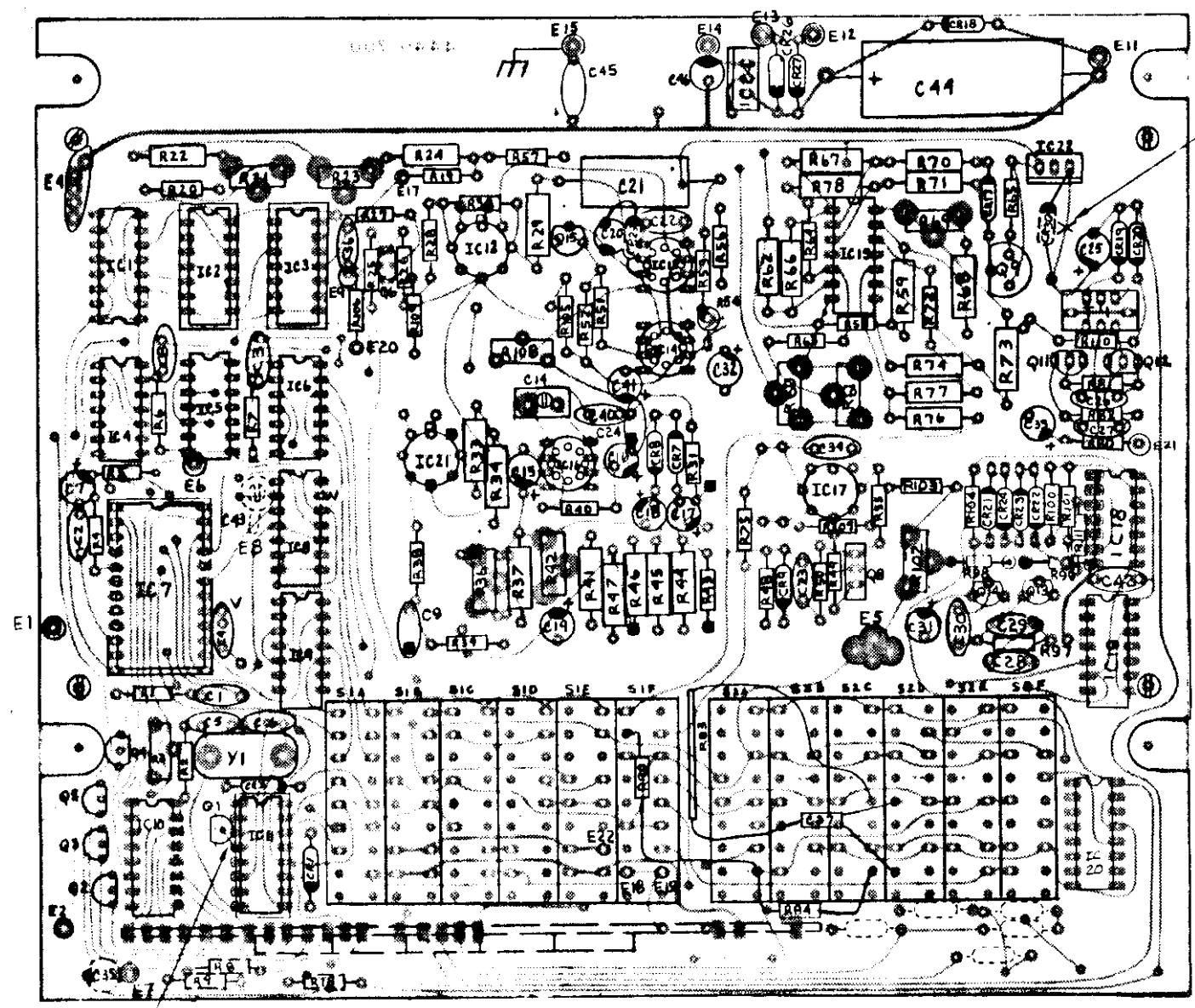

CUT CLAD FAR SIDE

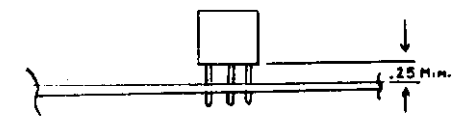

ALL TRANSISTOR AND TO-18
Q1-Q18, IC12, IC21, IC13, IC14, IC17, IC14

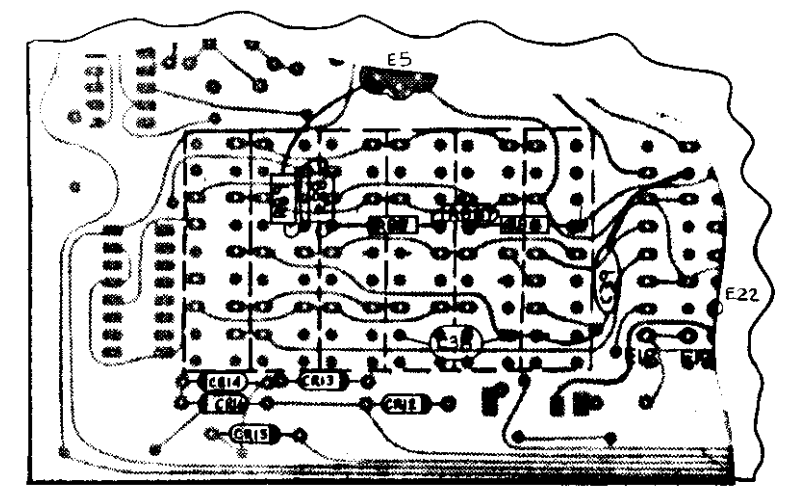

SHOWN IS PARTIAL PCB. ASSY. OF COMPONENT MOUNTED ON BOTTOM OF SWITCHES. VIEWED FROM BOTTOM SIDE.

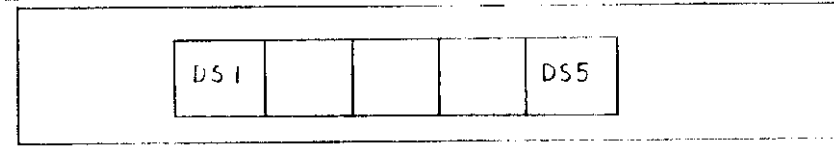
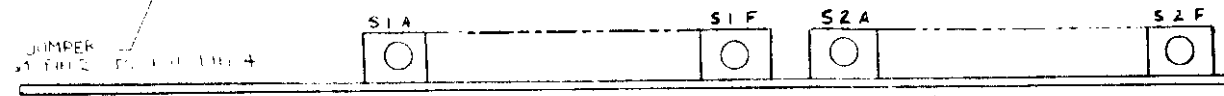

SHOWN IS PCB. ASSEMBLY 4440-600 VIEWED IS TOP SIDE
CLAD SHOWN IS BOTTOM SIDE

- 4. FOR PARTS LIST SEE 4440-400 SHT 1-5.
- 3. FOR ASSEMBLY DRAWING SEE 4440-400 SHT 8.
- 2. FOR WIRE TABLE SEE 4440-081
- 1. FOR SCHEMATIC SEE DRAWING 4440-070

NOTES:

MATERIAL	DRAWN MC 1/4	<p>Valhalla Scientific Inc. SAN DIEGO, CALIFORNIA</p>
	CHECKED Rm 6/82	
	APPR	
FINISH	ASSEMBLY PCB. DIGITAL MULTIMETER 4440	
	SCALE NONE	CODE IDENT NO. 53804
	SHEET 1 OF 1	SIZE D
		DRAWING NO. 4440-600
		REV K

8 7 6 5 4 3 2 1

REVISIONS			
ZONE	LTR	DESCRIPTION	DATE
F	ECO	02	Rm 10/81

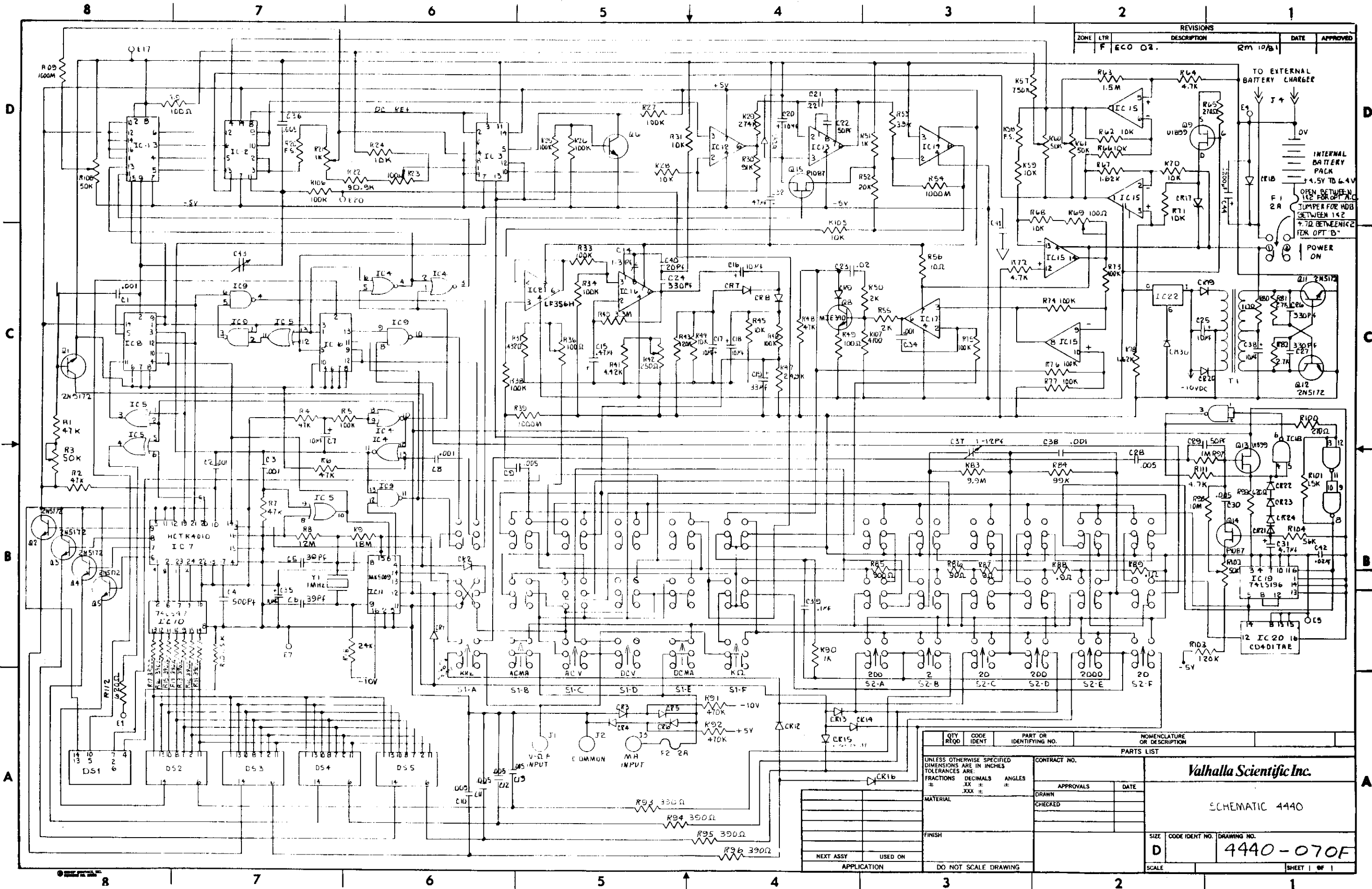

QTY REQD		CODE IDENT	PART OR IDENTIFYING NO.	NOMENCLATURE OR DESCRIPTION
PARTS LIST				
UNLESS OTHERWISE SPECIFIED DIMENSIONS ARE IN INCHES TOLERANCES ARE:		CONTRACT NO.		
FRACTIONS	DECIMALS	ANGLES	APPROVALS	
±	±	±	DATE	
±	±	±	DRAWN	
MATERIAL		CHECKED		
FINISH		NEXT ASSY		
APPLICATION		USED ON		
DO NOT SCALE DRAWING		SCALE		

Valhalla Scientific Inc.

SCHEMATIC 4440

SIZE: **D** CODE IDENT NO.: **4440-070F** DRAWING NO.

SHEET 1 OF 1



PARTS LIST

UNIT ASSY "DC"

MODEL
4440

DWG NO
4440-400

REV
L

#	REF DES	VALHALLA PART NO	DESCRIPTION	CODE IDENT	MFG PART NO	QTY			REMARKS
						I	N	I	
1									
2	Q17	3-10010	Transistor	04713	2N4402	1			
3	C1-2, 8, 34	2-10009	Cap. Cerm. .001UF	56289	5GAD10	4			
4	C 4	2-10002	Cap. Cerm. 500pf	56289	5GAT50	1			
5	C 5, 6	2-10010	Cap. Cerm. 39pf	56289	5GAQ39	2			
6	C7, 16-18, 20								
7	C9, 13, 28, 30,	2-30001	Cap. Tan 10uf25V	05397	T360B106M025AS	9			
8	C 14	2-10000	Cap. Cerm. .005uF	56289	5GAD50	9			
9	C 15	2-70002	Cap. Var. 1-3pf	Johnson	278-0103-005	1			
10	C19	2-30006	Cap. Tan. .47uf 10V	05397	T360B474M010AS	1			
11	C21	2-30002	Cap. Tan 33uf 10V	05397	T360B336M010AS	1			
12	C 22, 29	2-50000	Cap. Poly .22uf	27556	PA2A224	1			
13	C 23, 42	2-10005	Cap. Cerm. 50pf	56289	5GAQ50	2			
14	C 24, 26, 27	2-10004	Cap. Cerm. .02uf	56289	5GAS20	2			
15	C 31	2-10007	Cap. Cerm. 330f	56289	5GAT33	3			
16	C32	2-30000	Cap. Tan 4.7uf 10V	05397	T360B475M010AS	1			
17	C 37	2-30003	Cap. Tan 47uf 10V	05397	T360B476M010AS	1			
18	C 38	2-70000	Cap. VAR 1-12pf	73899	VC58G	1			
19	C 39	2-20011	Cap. Mica 1000pf	81349	CM06D102J03	1			
20	C40	2-60002	Cap. Paper .1uf	56289	225P10491	1			
21	C 43	2-10003	Cap. Cerm. 20pf	56289	5GAQ20	1			
		2-70001	Cap. Var. 2-12pf.		21FG010	1			

NOTES: INDICATE COMPONENT USED IN "TRMS" OPTION
 INDICATE COMPONENT USED IN "F" OPTION
 △ INDICATE COMPONENT ON DISPLAY P.C.B. 4440-701



PARTS LIST

UNIT AASY "DC"

MODEL

4440

DWG NO

4440-400

REV

L

#	REF DES	VALHALLA PART NO	DESCRIPTION	CODE IDENT	MFG PART NO	QTY			REMARKS
						I	N	I	
22	C44	2-40004	Cap. Elec. 2200uf	30039	16T2200	1			
23	CR1, 2, 7-9, 12	16, 19, 20	21, 22, 23, 29, 30						
		3-20000	DIODE	07263	1N4148	17			
24	CR 3 6, 18	3-20002	DIODE RECT.	07263	1N4001	5			
25	CR17	3-20041	DIODE, ZENNER, Ref 6.3V	07263	1N825	1			
26	DS1 Δ	5-01020	LED 1 Display	28480	5082-7656C	1			
27	DS 2-5 Δ	5-01010	LED 0-9 Display	28480	5082-7650C	4			
28	F 1 Δ	5-04001	Fuse, 2A	75915	3GA2A	2			
29	IC 1	3-30022	IC Level Shifter	86684	CD4054AE	1			
30	IC 2, 3	3-30023	IC Quad Switchch	86684	CD4066BF	2			
31	IC4	3-30024	IC Quad NOR	86684	CD4001AE	1			
32	IC 5	3-30025	IC Quad EX. OR	86684	CD4030AE	1			
33	IC 6, 8	3-30026	IC Dual D Flip Flop	86684	CD4013AE	2			
34	IC 7	3-30029	IC LSI	Hughes	HCTR4010	1			
35	IC 9	3-30027	IC Quad NAND	86684	CD4011AE	1			
36	IC 10	3-30106	IC Decoder Driver	01295	74LS47	1			
37	IC11	3-30012	IC LSI Timer	Mostec	Mk 5009P	1			
38	IC 12, 21, 17	3-30074	IC-Op Amp	27014	LF356H	3			
39	IC 13	3-30017	IC Op-Amp	26014	LM308N	1			
40	IC 14, 16	3-30013	IC Op-Amp	27014	LM301H	2			
41	IC15	3-30031	IC Quad Op-Amp	27014	LM324N	1			
42	IC 18	3-30002	IC Quad NAND	27014	SN7400N	1			
43	IC 19	3-30032	IC Decade Counter	01295	SN4LS196	1			

NOTES:



PARTS LIST

UNIT ASSY "DC"

MODEL

4440

DWG NO

4440-400

REV

L

#	REF DES	VALHALLA PART NO	DESCRIPTION	CODE IDENT	MFG PART NO	QTY			REMARKS
						I	N	N	
44	IC 20	3-30033	IC Decade Counter	86684	CD4017AE	1			
45	IC 22	3-30035	IC Voltage Reg.	27014	LM320-5.0T	1			
46	J1 \triangle	5-10030	Banana Jack Red	05276	1581-Red	1			
47	J2 \triangle	5-10032	Banana Jack Blue	05276	1581-BLUE	1			
48	J3 \triangle	5-10031	Banana Jack Wht.	05276	1581-Wht	1			
49	J4	5-10033	Connector Pwr	82389	712A	1			
50	Q1-6,11,12	3-10003	Transistor NPN	04713	2N5172	8			
51	Q8	3-10015	Transistor NPN	04713	MJE3439	1			
52	Q9, 13	3-10000	Transistor FET	15818	U1899E	2			
53	Q14,15	3-10004	Transistor FET	15818	P1087E	2			
54	R120	1-01004	Res Fxd 4.7K 1/4W	81349	RC07GF4R7J	1			
55	R1,2,4,6,7,48	1-01073	Res Fxd 47K 1/4W 5%	81349	RC07GF473J	6			
56	R3,60,61,102,108	1-50005	Res Var 50K 20%	71450	X201R503	5			
57	R5,25-27,38,106	1-01081	Res Fxd 100K 1/4W 5%	81349	RC07GF104J	7			
58	R8	1-01120	Res Fxd 12M 1/4W5%	81349	RC07GF126J	1			
59	R10, 101	1-01043	Res Fxd 1.5K 1/4W 5%	81349	RC07GF152J	2			
60	R18	1-01067	Res Fxd 24K 1/4W 5%	81349	RC07GF243J	1			
61	R19,49	1-01021	Res Fxd 100 1/4W 5%	81349	RC07GF101J	2			
62	R20,58		Factory Select			2			
63	R21	1-50002	Res Var 1K20%	71450	X201R102	1			
64	R22	1-10038	Res Fxd 90.9K .1%	81349	RN60C9092B	1			

NOTES:



PARTS LIST

UNIT ASSY "DC"

MODEL

4440

DWG NO

4440-400

REV

L

#	REF DES	VALHALLA PART NO	DESCRIPTION	CODE IDENT	MFG PART NO	QTY			REMARKS
						I	N	N	
65	R23,36,69	1-50000	Res Var 100 20%	71450	X201R101	3			
66	R24,44,45,59								
	62,66,68,70,71	1-10037	Res Fxd 10K .1%	81349	RN60C1002B	9			
67	R28,31,105,110	1-01061	Res Fxd 10K 1/4W 5%	81349	RC07GF103J	4			
68	R29	1-10039	Res Fxd 274K 1%	81349	RN50C2743F	1			
69	R30	1-01080	Res Fxd 91K 1/4W 5%	81349	RC07GF913J	1			
70	R33,34,46,73								
	74, 76,77	1-10049	Res Fxd 190K .1%	81349	RN60C1003B	7			
71	R37	1-10041	Res Fxd 432	81349	RN60C4320F	1			
72	R39,109,54	1-01128	Res Fxd 1000M	81349	RC07GF108J	3			
73	R40	1-01109	Res Fxd 3.3M 1/4W 5%	81349	RC07GF335J	1			
74	R41	1-10040	Res Fxd 4.42K	81349	RN60C4421F	1			
75	R42	1-50007	Res Var 250 20%	71450	X201R251	1			
76	R43,103	1-01082	Res Fxd 120K 1/4W 5%	81349	RC07GF124J	2			
77	R47	1-10028	Res Fxd 24.9K 1%	81349	RN60C2492F	1			
78	R50,55	1-01045	Res Fxd 2K 1/4W 5%	81349	RC07GF202J	2			
79	R51	1-01041	Res Fxd 1K 1/4W 5%	81349	RC07GF103J	1			
80	R52	1-01065	Res Fxd 20K 1/4W 5%	81349	RC07GF203J	1			
81	R53	1-01051	Res Fxd 3.9K	81349	RC07GF392J	1			
82	*	1-10090	Matched Atten. Set						
			9.9M, 1K, 99K						
83	R56,80,113,121	1-01007	Res Fxd 10 1/4W 5%	81349	RC07GF100J	4			
84	R57	1-01097	Res Fxd 750K 1/4W 5%	81349	RC07GF754J	1			

NOTES:



PARTS LIST

UNIT ASSY "DC"

MODEL

4440

DWG NO
4440-400

REV
L

#	REF DES	VALHALLA PART NO	DESCRIPTION	CODE IDENT	MFG PART NO	QTY			REMARKS
						I	N	I	
85	R63	1-01102	Res Fxd 1.5M 1/4W 5%	81329	RC07GF155J	1			
86	R64, 72, 111	1-01053	Res Fxd 4.7K 1/4W 5%	81349	RC07GF472J	3			
87	R65, 100	1-01028	Res Fxd 270 1/4W 5%	81349	RC07GF271J	2			
88	R67, 78	1-10036	Res Fxd 1.62K .1%	81349	RN60C1621B	2			
89	R81, 82	1-01048	Res Fxd 2.7K 1/4W 5%	81349	RC07GF272J	2			
90	*R83	1-10090	Res Fxd 9.9M	00002		1			
91	*R84	1-10090	Res Fxd 99K	00002		1			
92	R85	1-20000	Res Fxd 900 .05%	00002	J110-900	1			
93	R86	STOCKED	Res Fxd 90 .5%	00002	J110-90	1			
94	R87	AS A	Res Fxd 9 .5%	00002	J110-9	1			
95	R88	SET	Res Fxd .9 .1 %	00002	J110-.9	1			
96	R89		Res Fxd .1 .1%	00002	J140-.1	1			
97	*R90	1-10090	Res Fxd 1K	00002		1			
98	R91, 92 Δ	1-01093	Res Fxd 470K 1/4W 5%	81349	RC07GF474J	2			
99	R93-96, 11-17 Δ	1-01031	Res Fxd 390 1/4W 5%	81349	RC07GF391J	11			
100	R97	1-01100	Res. Fxd 1M 1/4W 5%	81349	RC07GF105J	1			
101	R98, 9	1-01119	Res Fxd 10M 1/4W 5%	81349	RC07GF106J	2			
102	R99, 112	1-01036	Res Fxd 620 1/4W 5%	81349	RC07GF621J	2			
103	R104	1-01075	Res Fxd 56K 1/4W 5%	81349	RC07GF563J	1			
104	R107	1-01033	Res Fxd 470 1/4W 5%	81349	RC07GF471J	1			
105		5-10278	Panel Nut	CBK	7099	1			
106	S1, 2	5-03005	Push Button Switch	71590	5-03005	2			
107	S3	5-03015	Toggle Switch	C&K	1201	1			

NOTES:



PARTS LIST

UNIT ASSY "DC"

MODEL
4440

DWG NO
4440-400

REV
L

#	REF DES	VALHALLA PART NO	DESCRIPTION	CODE IDENT	MFG PART NO	QTY		REMARKS	
						I	N	I	N
108		5-10277	Silver Button	71590	B-426	12			
109	T1	4-20006	Transformer	53504	4440-010	1			
110	Y1	5-02000	1MHz Crystal	81349	HC6-1MHz	1			
111		5-10199	Fiber Washer	Smith	2161	8			
112			#4 Self Tapping Screw	1/2"lg.		4			
113			#4 Washer, Split lock			4			
114		5-10198	1/8" Spacer	Smith	8880	4			
115	△	5-10363	Fuse Holder, IN LINE, 2A	LITTLEFUSE	155100A	1			
116		4-30009	P.C. Board	53504	4440-700H	1			
117	△	4-30010	P.C. Board	53504	4440-701F	1			
118		5-10042	24 Pin IC Socket	01295	C8524-01	1			
119		5-10008	16 Pin IC Socket	01295	C8516-01	1			
120		5-10041	14 Pin IC Socket	01295	C8514-01	3			
121		5-10049	Battery Box	Wkman	L103	1			
122									
123		4-10467	Front Panel	53504	4440-100	1			
124		4-10130	Chassis	LaFrance	CH-250 Beige	1			
125		4-10235	Rear Panel	53504	4440 -214	1			
126		5-10521	Fuse Holder, PANEL MFG.	LITTLEFUSE	342004	1			
127		5-10239	Velcro Hook United Textile	Textile	VN06330HK	8	Inches		
128		5-10240	Velcro Loop United Textile	Textile	VN06330LP	8	Inches		
129		4-10130	Chassis (Includes)	LaFrance	CH250 Beige	1			
130			Handle (60128)			1			

NOTES:



PARTS LIST

UNIT ASSY "DC"

MODEL

4440

DWG NO

4440-400

REV

#	REF DES	VALHALLA PART NO	DESCRIPTION	CODE IDENT	MFG PART NO	QTY			REMARKS
						I	N	N	
131			Spring (60157)			2			
132			Button (60156)			2			
133			#4 Screw (60164)			2			
134			Cap (60170)			2			
135			Feet (60129)			4			
136						4			
137			Top Cover (60119-1)			1			
138			Spacers (60130-2)			8			
139			Side Expanders (60120)			2			
140			Bottom Cover (60119-2)			1			
141									
142			WIRE:						
143			ORN 22AWG						17 in.
144			BLUE 22AWG						20 in.
145			BLACK 22AWG						28 in.
146			RED 22AWG						11 in.
147			WHITE 22AWG						5 in.
148			BUSS 22AWG						1 in.
149			BUSS 14AWG						5 in.
150			Sticker Batt. Replacement			1			
151			Screw, Phil Pan Blk.			2			6 x 32 x 1/2
152			Washer, Split Lock			2			#6
153			Nut, Radio Hex			2			6-32

NOTES:

SEE ASSY DWG FOR SHEETS AND 8 and 9

SMT 7 OF 9



PARTS LIST

OPTION 20Hz
TRMS TO DC CONVERTER

MODEL

4440

DWG NO

4440-604

REV

A

#	REF DES	VALHALLA PART NO	DESCRIPTION	CODE IDENT	MFG PART NO	QTY			REMARKS
						I	N	I N	
1	C1	2-10000	CAP. CERM .005µf	56289	5GAD50	1			
2	C2,3	2-30007	CAP. TAN 2.2µf	05397	T390A225M01AS	2			
3	C4,5	2-60002	CAP. PAPER .1µf	56289	225P10491	2			
4	C6	2-30008	CAP. TAN 6.8µf	05397	T390B685M01AS	1			
5	C7	2-10002	CAP. CERM 500pf	56289	5GAT50	1			
6									
7	IC1	3-30074	IC FET OP-AMP	27014	LF356H	1			
8	IC2	3-30045	IC RMS TO DC CONV.	ANALOG	AD536JD	1			
9									DEVICES
10	R1	1-01081	RES FXD 100K 1/4W 5%	81349	RC07GF104J	1			
11	R2	1-01128	RES FXD 1000m1/4W 5%	82349	RC07GF108J	1			
12	R3	1-10053	RES FXD 2.43K 1/4W 1%	81349	RN60C2431F	1			
13	R4	1-10054	RES FXD 22.1K 1/4W 1%	81349	RN60C2212F	1			
14	R5	1-50000	RES VAR 100Ω 20%	71450	X201R101	1			
15	R6	1-10055	RES FXD 113K 1/4W 1%	81349	RN60C1133F	1			
16	R7	1-50004	RES VAR 500Ω 20%	71450	X201R501	1			
17	R8	1-10056	RES FEX 12.1K 1/4W 1%	81349	RN60C1212F	1			
18	R9	1-01020	RES FEX 100Ω 1/4W 5%	81349	RC07GF101F	1			
19	R10	1-01100	RES FEX 1M 1/4W 5%	81349	RC07GF105F	1			
20	R11	1-50005	RES VAR 50K 20%	71450	X201R503	1			
21									
22									

NOTES: FOR SCHEMATIC SEE DWG. NO 4440-071



PARTS LIST

OPTION 20Hz TRMS TO DC CONVERTER

MODEL

4440

DWG NO

4440-604

REV

A

#	REF DES	VALHALLA PART NO	DESCRIPTION	CODE IDENT	MFG PART NO	QTY			REMARKS
						I	N	I N	
23		4-30021	P.C. BOARD	53504	4440-704	1			
24		5-10198	1/8 STANDOFF	83330	8880	8			

NOTES:

Federal Supply Codes for Manufacturers

00656 Aerovox Corp. New Bedford, Massachusetts	04713 Motorola Inc. Phoenix, Arizona	08261 Spectra Strip Corp. Garden Grove, California	12697 Clarostat Mfg. Co. Dover, New Hampshire
00686 Film Capacitors, Inc. Passaic, New Jersey	04946 Standard Wire & Cable Los Angeles, California	08530 Reliance Mica Corp. Brooklyn, New York	12969 Unitrode Corp. Watertown, Massachusetts
00779 AMP Inc. Harrisburg, Pennsylvania	05276 Pomona Electronics Co., Inc. Pomona, California	08806 General Electric Co. Cleveland, Ohio	13103 Thermalloy Co., Inc. Dallas, Texas
00853 Sangamo Electric Company Pickens, South Carolina	05277 Westinghouse Electric Corp. Youngwood, Pennsylvania	09026 Babcock Electronics Corp. Costa Mesa, California	13327 Solitron Devices Inc. Tappan, New York
01121 Allen-Bradley Co. Milwaukee, Wisconsin	05397 Kemet, Union Carbide Corp. New York, New York	09214 G. E. Co. Semi-Conductor Auburn, New York	13454 Texas Crystals River Grove, Illinois
01255 Litton Industries, Inc. Beverly Hills, California	05574 Viking Industries Chatsworth, California	09353 C and K Components Watertown, Massachusetts	13511 Amphenol Cadre Div. Los Gatos, California
01281 TRW Electronic Comp. Semiconductor Operations Lawndale, California	05820 Wakefield Engineering Inc. Wakefield, Massachusetts	09922 Burndy Corp. Norwalk, Connecticut	13606 Use 56289 Sprague Electric Co. Concord, New Hampshire
01295 Texas Instruments, Inc. Dallas, Texas	06001 General Electric Co. Columbia, South Carolina	09969 Dale Electronics Inc. Yankton, S. Dakota	14099 Semtech Corp. Newbury Park, California
01686 RCL Electronics Inc. Manchester, New Hampshire	06383 Panduit Corp. Tinley Park, Illinois	11236 CTS of Berne Berne, Indiana	14655 Cornell-Dublier Electronics Newark, New Jersey
02114 Ferroxcube Corp. Saugerties, New York	06473 Bunker Ramo Corp. Chatsworth, California	11403 Best Products Co. Chicago, Illinois	14752 Electro Cube Inc. San Gabriel, California
02131 General Instrument Corp. Westwood, Maine	06555 Beede Electrical Instrument Co. Penacook, New Hampshire	11503 Keystone Columbia Inc. Warren, Michigan	14936 General Instrument Corp. Hicksville, New York
02799 Aero Capacitors, Inc. Chatsworth, California	06743 Clevite Corp. Cleveland, Ohio	11532 Teledyne Relays Hawthorne, California	15801 Fenwal Electronics Inc. Framingham, Massachusetts
03508 General Electric Co. Syracuse, New York	07088 Kelvin Electric Company Van Nuys, California	11711 General Instrument Corp. Hicksville, New York	15818 Teledyne Semiconductors Mountain View, California
03797 Genisco Technology Corp. Compton, California	07256 Silicon Transistor Corp. Chelmsford, Massachusetts	12014 Chicago Rivet & Machine Co. Bellwood, Illinois	15849 Useco Inc. Van Nuys, California
03877 Transistron Electronic Corp. Wakefield, Massachusetts	07263 Fairchild Semiconductor Mountain View, California	12060 Diodes, Inc. Chatsworth, California	15898 International Business Machines Corp. Essex Junction, Vermont
03911 Clairex Corp. Mt. Vernon, New York	07344 Bircher Co., Inc. Rochester, New York	12136 Philadelphia Handle Co. Camden, New Jersey	16332 Replaced by 28478
04009 Arrow Hart Inc. Hartford, Connecticut	07597 Burndy Corp. Rochester, New York	12405 Hysol Corporation El Monte, California	16473 Cambridge Scientific Ind. Cambridge, Maryland
04217 Essex International Inc. Anaheim, California	07716 I R C Incorporated Burlington, Iowa	12406 Elpac, Incorporated Fullerton, California	16758 Delco Electronics Kokomo, Indiana
04222 AVX Corp. Myrtle Beach, Florida	07910 Teledyne Semiconductor Hawthorne, California	12615 U.S. Terminals Inc. Cincinnati, Ohio	17856 Siliconix, Inc. Santa Clara, California
04423 Telonic Industries Laguna Beach, California	08065 Accurate Rubber and Plastics Co. San Diego, California	12617 Hamlin Inc. Lake Mills, Wisconsin	18324 Signetics Corp. Sunnyvale, California

Federal Supply Codes for Manufacturers (cont.)

18612 Vishay Intertechnology Inc. Malvern, Pennsylvania	32539 Mura Corp. Great Neck, New York	63743 Ward Leonard Electric Co., Inc. Mount Vernon, New York	73899 JFD Electronics Co. Brooklyn, New York
18722 R C A Mountaintop, Pennsylvania	32897 Erie Technological Products, Inc. Carlisle, Pennsylvania	65092 Weston Instruments Inc. Newark, New Jersey	73949 Guardian Electric Mfg. Co. Chicago, Illinois
18927 GTE Sylvania Inc. Titusville, Pennsylvania	32997 Bourns Inc. Riverside, California	70563 Amperite Company Union City, New Jersey	74276 General Instrument Corp. Neptune, New Jersey
21604 Bucheys Stamping Co. Columbus, Ohio	33173 General Electric Co. Owensboro, Kentucky	70903 Belden Corp. Geneva, Illinois	74306 Piezo Crystal Co. Carlisle, Pennsylvania
21845 Solitron Devices Inc. Riviera Beach, Florida	34333 Silicon General Westminister, California	71279 Cambridge Thermionic Corp. Cambridge, Massachusetts	74970 Johnson E.F., Co. Waseca, Minnesota
22767 ITT Semiconductors Palo Alto, California	34335 Advanced Micro Devices Sunnyvale, California	71400 Bussmann Mfg. Saint Louis, Missouri	75042 TRW Electronics Components IRC Fixed Resistors Philadelphia, Pennsylvania
23936 Pamotor Div. Burlingham, California	34802 Electromotive Inc. Kenilworth, New Jersey	71450 CTS Corp. Elkhart, Indiana	75378 CTS Knights Inc. Sandwich, Illinois
24355 Analog Devices Inc. Norwood, Massachusetts	37942 P.R. Mallory & Co., Inc. Indianapolis, Indiana	71468 ITT Cannon Electric Inc. Santa Ana, California	75382 Kulka Electric Corp. Mount Vernon, New York
24655 General Radio Concord, Massachusetts	43543 Nytronics Inc. Geneva, New York	71482 Clare, C.P. & Co. Chicago, Illinois	75915 Littlefuse Inc. Des Plaines, Illinois
25088 Siemen Corp. Isilen, New Jersey	44655 Ohmite Mfg. Co. Skokie, Illinois	71590 Centrelab Electronics Milwaukee, Wisconsin	76055 Mallory Controls Frankfort, Indiana
25403 Amperex Electronic Corp. Slatersville, Rhode Island	49671 RCA Corp. New York, New York	71707 Coto Coil Co., Inc. Providence, Rhode Island	76493 J.W. Miller Company Los Angeles, California
25684 Victoreen Instrument Co., Inc. Oak Lawn, Illinois	49956 Raytheon Company Lexington, Massachusetts	71744 Chicago Miniature Lamp Works Chicago, Illinois	76854 Oak Industries Inc. Crystal Lake, Illinois
27014 National Semiconductor Corp. Santa Clara, California	50088 Mostek Corp. Carrollton, Texas	71785 TRW Electronics Components Chicago, Illinois	77342 Potter & Brumfield Div. Princeton, Indiana
27556 IMB Electronic Products Santa Fe Springs, California	50579 Litronix Inc. Cupertino, California	72005 Wilber B. Driver Co. Newark, New Jersey	77638 General Instrument Corp. Rectifier Division Brooklyn, New York
27264 Molex Products Downers Grove, Illinois	51605 Scientific Components Inc. Linden, New Jersey	72259 Nytronics Inc. Pelham Manor, New Jersey	78488 Stackpole Carbon Co. Saint Marys, Pennsylvania
28213 Minnesota Mining & Mfg. Co. St. Paul, Minnesota	53021 Sangamo Electric Co. Springfield, Illinois	72619 Dialight Div. Brooklyn, New York	78553 Eaton Corp. Cleveland, Ohio
28480 Hewlett Packard Co. Palo Alto, California	53504 Valhalla Scientific, Inc. San Diego, California	72982 Erie Tech. Products Inc. Erie, Pennsylvania	80031 Electro-Midland Corp. Mepco Div. Norristown, New Jersey
29083 Monsanto Co., Inc. Santa Clara, California	54294 Cutler-Hammer Inc. Selma, North Carolina	73138 Bechman Instrument Inc. Helipot Division Fullerton, California	56289 Sprague Products North Adams, Massachusetts
29604 Stackpole Components Co. Raleigh, North Carolina	55026 Simpson Electric Co. Elgin, Illinois	73445 Amperex Electronic Corp. Hicksville, New York	80294 Bourns Inc., Instrument Div. Riverside, California
30323 Illinois Tool Works, Inc. Chicago, Illinois	56289 Sprague Electric Co. North Adams, Massachusetts	73734 Federal Screw Products, Inc. Chicago, Illinois	81073 Grayhill, Inc. La Grange, Illinois
30983 Electra/Midland San Diego, California	58474 Superior Electric Co. Bristol, Connecticut		

Federal Supply Codes for Manufacturers (cont.)

81095
Triad Transformer Corp.
Venice, California

81312
Winchester Electronics
Div. of Litton Industries Inc.
Oakville, Connecticut

81483
International Rectifier Corp.
Los Angeles, California

81741
Chicago Lock Co.
Chicago, Illinois

82389
Switchcraft Inc.
Chicago, Illinois

82877
Rotron Inc.
Woodstock, New York

82879
ITT Royal Electric Div.
Pawtucket, Rhode Island

83003
Varo Inc.
Garland, Texas

83298
Bendix Corp.
Eatontown, New Jersey

83330
Herman H. Smith, Inc.
Brooklyn, New York

83594
Burrhoughs Corp.
Plainfield, New Jersey

83740
Union Carbide Corp.
New York, New York

84171
Arco Electronics
Great Neck, New York

84411
TRW Electronic Components
Ogallala, Nebraska

84613
Fuse Indicator Corp.
Rockville, Maryland

84682
Essex International Inc.
Peabody, Massachusetts

86684
Radio Corp. of America
Harrison, New Jersey

88219
Gould Inc.
Trenton, New Jersey

88245
Litton Systems Inc.
Useco Div.
Van Nuys, California

88419
Cornell-Dubilier Electronic Div.
Fuquay-Varian, North Carolina

89730
G.E. Co.
Newark, New Jersey

90201
Mallory Capacitor Co.
Indianapolis, Indiana

56365
Square D Co.
Chicago, Illinois

90303
Mallory Battery Co.
Tarrytown, New York

91094
Essex International Inc.
Newmarket, New Hampshire

91293
Johanson Mfg. Co.
Boonton, New Jersey

91506
Augat Inc.
Attleboro, Massachusetts

91637
Dale Electronics Inc.
Columbus, Nebraska

91662
Elco Corp.
Willow Grove, Pennsylvania

71468
Gremar Mfg. Co., Inc.
ITT Cannon/Gremar
Santa Ana, California

91802
Industrial Devices, Inc.
Edgewater, New Jersey

91833
Keystone Electronics Corp.
New York, New York

91929
Honeywell Inc.
Micro Switch Div.
Freeport, Illinois

92194
Alpha Wire Corp.
Elizabeth, New Jersey

93332
Sylvania Electric Products
Woburn, Massachusetts

94988
Wagner Electric Corp.
Tung-Sol Div.
Newark, New Jersey

95146
Alco Electronic Products Inc.
Lawrence, Massachusetts

95275
Vitramon Inc.
Bridgeport, Connecticut

95303
RCA Corp.
Receiving Tube Div.
Cincinnati, Ohio

95348
Gordo's Corp.
Bloomfield, New Jersey

95712
Bendix Corp.
Franklin, Indiana

97913
Industrial Electronic
Hardware Corp.
New York, New York

97945
Penwalt Corp.
SS White Industrial Products Div.
Piscataway, New Jersey

98278
Malco A. Microdot Co., Inc.
Connector & Cable Div.
Pasadena, California

98291
Sealectro Corp.
Mamaroneck, New York

98388
Royal Industries
Products Div.
San Diego, California

98978
IERC
Burbank, California

99120
Plastic Capacitors, Inc.
Chicago, Illinois

99217
Bell Industries Elect.
Burbank, California

99392
STM
Oakland, California

99515
ITT Jennings Monrovia Plant
Monrovia, California

99779
Use 29587
Bunker-Ramo Corp.
Landsdowne, Pennsylvania

99942
Centrelab Semiconductor
El Monte, California